

ALTO SHAAM®

Combitherm®

**Boiler-
FREE**

COMBINATION OVEN/STEAMERS

**INSTALLATION
MAINTENANCE
AND
SERVICE MANUAL**



ELECTRIC

MODELS:

6•05ML

6•10iNML

10•10iN

7•14i

**ELECTRIC
SMOKER**

MODELS:

6•10iN/SK

10•10iN/SK

7•14i/SK

W164 N9221 Water Street • P.O. Box 450 • Menomonee Falls, Wisconsin 53052-0450 • U.S.A.

PHONE: (262)251-3800 (800)558-8744 U.S.A./CANADA FAX: (262)251-7067 (800)329-8744 U.S.A.

www.alto-shaam.com

ALTO SHAAM® COMBITHERM® INSTALLATION

DELIVERY

This Alto-Shaam appliance has been thoroughly tested and inspected to insure only the highest quality unit is provided. Upon receipt, check for any possible shipping damage and report it at once to the delivering carrier. See *Transportation Damage and Claims section located in this manual.*

This appliance, complete with unattached items and accessories, may have been delivered in one or more packages. Check to ensure that all standard items and options have been received with each model as ordered.

Save all the information and instructions packed with the appliance. Complete and return the warranty card to the factory as soon as possible to assure prompt service in the event of a warranty parts and labor claim.

This manual must be read and understood by all people using or installing the equipment model. Contact the Alto-Shaam service department if you have any questions concerning installation, operation, or maintenance.

NOTE: All claims for warranty must include the full model number and serial number of the unit.

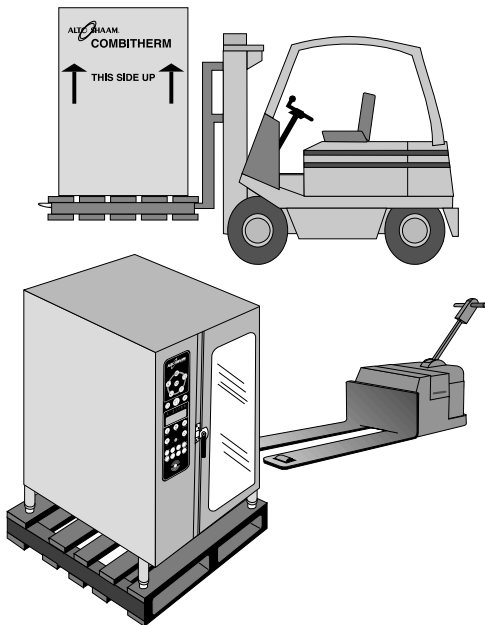

UNPACKING

1. Carefully remove the appliance from the carton or crate.

NOTE: Do not discard the carton and other packaging material until you have inspected the unit for hidden damage and tested it for proper operation.

2. **The oven must remain on the pallet while being moved to the installation site by fork lift or pallet lift truck.**

Note dimensions required for doorways and aisles for access of the oven and pallet to the installation site. Transport the oven in an upright and level position only. *Do not tilt the oven.*

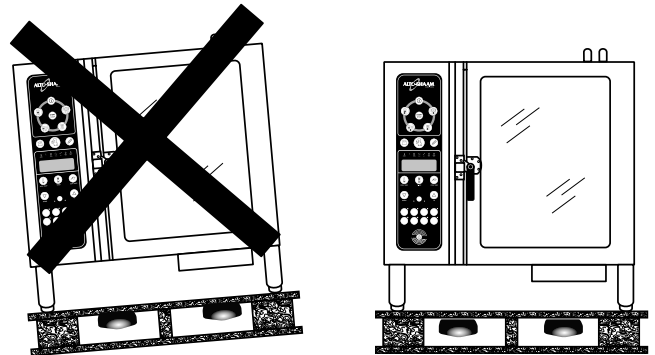

With the oven on the original pallet, remove the carton and all packaging materials. Open the oven door and remove all documents and other materials from the oven interior. Remove the roll-in cart if so equipped.

3. Read all instructions in this manual carefully before initiating the installation of this appliance.

DO NOT DISCARD THIS MANUAL.

This manual is considered to be part of the appliance and is to be provided to the owner or manager of the business or to the person responsible for training operators. *Additional manuals are available from the Alto-Shaam service department.*

4. Remove all protective plastic film, packaging materials, and accessories from the appliance before connecting electrical power. Store any accessories in a convenient place for future use.

SAFETY PROCEDURES AND PRECAUTIONS

Knowledge of proper procedures is essential to the safe operation of electrically and/or gas energized equipment. In accordance with generally accepted product safety labeling guidelines for potential hazards, the following signal words and symbols may be used throughout this manual.

 **DANGER** Used to indicate the presence of a hazard that will cause severe personal injury, death, or substantial property damage if the warning included with this symbol is ignored.

 **WARNING** Used to indicate the presence of a hazard that can cause personal injury, possible death, or major property damage if the warning included with this symbol is ignored.

 **CAUTION** Used to indicate the presence of a hazard that can or will cause minor or moderate personal injury or property damage if the warning included with this symbol is ignored.

CAUTION Used to indicate the presence of a hazard that can or will cause minor personal injury, property damage, or a potential unsafe practice if the warning included with this symbol is ignored.

NOTE: Used to notify personnel of installation, operation, or maintenance information that is important but not hazard related.

1. This appliance is intended to cook, hold or process foods for the purpose of human consumption. No other use for this appliance is authorized or recommended.
2. This appliance is intended for use in commercial establishments where all operators are familiar with the purpose, limitations, and associated hazards of this appliance. Operating instructions and warnings must be read and understood by all operators and users.
3. Any troubleshooting guides, component views, and parts lists included in this manual are for general reference only and are intended for use by qualified technical personnel.
4. This manual should be considered a permanent part of this appliance. This manual and all supplied instructions, diagrams, schematics, parts lists, notices, and labels must remain with the appliance if the item is sold or moved to another location.

COMBITHERM® INSTALLATION

BASIC INSTALLATION SITE REQUIREMENTS

HOOD INSTALLATION IS REQUIRED

- Installation surface must be level.
- Do not install adjacent to flammable surfaces.
- Deep fat fryers or similar heat producing equipment must not be installed in the immediate vicinity of the hand shower.



The oven must remain on the pallet while being moved to the installation site with fork lift or pallet lift truck.

Do not tilt the oven.

VENTILATION REQUIREMENTS

A steam ventilation hood is mandatory for the operation of the oven. The ventilation hood must be installed in accordance with local building codes for steam exhaust and must protrude 12-inches to 20-inches (300mm to 500mm) over the front side of the oven. A grease filter must be located in the protruding area of the hood. Grease filters should be thoroughly cleaned on a regular basis following manufacturer's instructions. Ventilation hoods must ensure an adequate amount of incoming air during operation and must be operated whenever the combination oven/steamer is used in order to avoid the accumulation of condensation in the hood area.

Where automatically operated appliances are vented through a ventilating hood or exhaust system equipped with a damper or with a power means of exhaust, provisions shall be made to allow the equipment to operate only when the damper is open to a position to properly vent the appliance and when the power means of exhaust is in operation.

IN ACCORDANCE WITH NFPA 54 COMMONWEALTH OF MASSACHUSETTS ONLY.

NOTE



If a ventless hood is to be installed, we recommend the Combitherm Ventless Hood for the appropriate model oven.

VHML5

Combitherm model 6•05, 6•10iNML, and 10•10iN

VHML-10

Combitherm model 7•14i

MODEL	VHML-5	VHML-10
Air Movement	530 CFM	1200 CFM
Drain Connection	3/4" (19,1mm) NPT	
Electrical	208-240 V.A.C. — 50/60 Hz, 1 ph	
	100 watts, .50 amps	240 watts, 1.0 Amps
Ship Weight	100 lb (45 kg)	126 lb (57 kg)
Replacement		
Filters GREASE	FI-24113	FI-23062
CHARCOAL	FI-24114	FI-24102

COMBITHERM® INSTALLATION

POSITIONING ON SITE

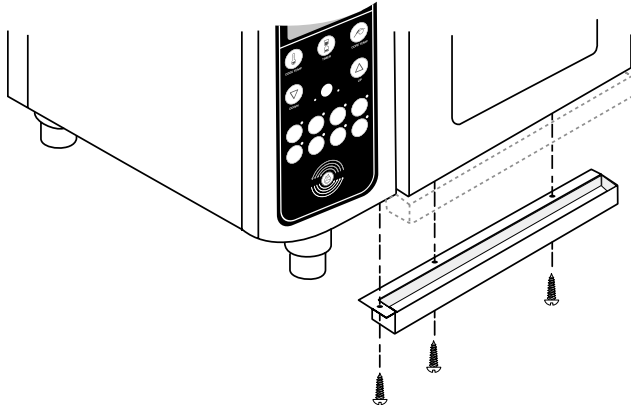

Before removing the oven from the pallet for positioning on site, it is important to remove the drip tray to prevent damage to the tray caused by the lifting forks. The drip tray is fastened to the bottom of the oven with three sheet metal screws as illustrated. This requirement pertains to the following models.

MODELS 6•05

6•10iNML	6•10iN/sk
10•10iN	10•10iN/sk
7•14i	7•14i/sk

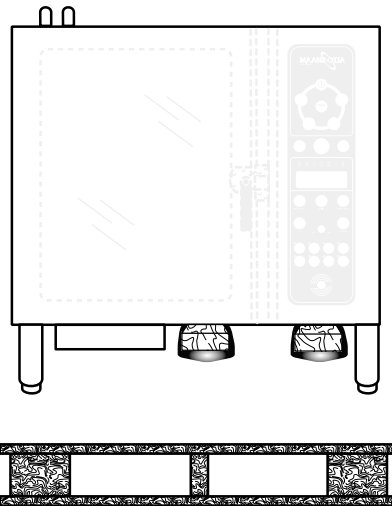
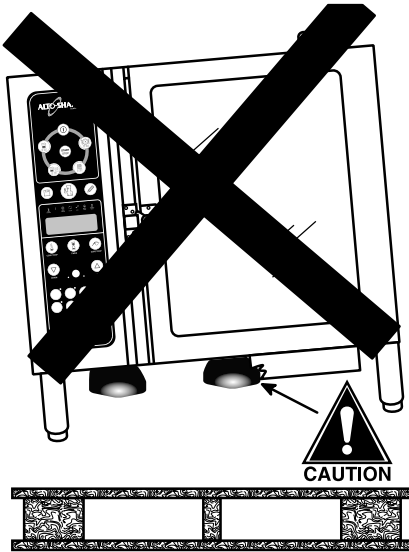

Lift the oven from the pallet with a fork lift or pallet lift truck positioned at the front of the oven. To avoid damage, position the lift forks to the left of the condenser as indicated in one of the two diagrams shown below. For additional damage protection, the use of two wooden boards, placed between the bottom of the oven and the lifting forks, is strongly recommended.



CAUTION

TO PREVENT PERSONAL INJURY, USE CAUTION WHEN MOVING OR LEVELING THIS APPLIANCE.

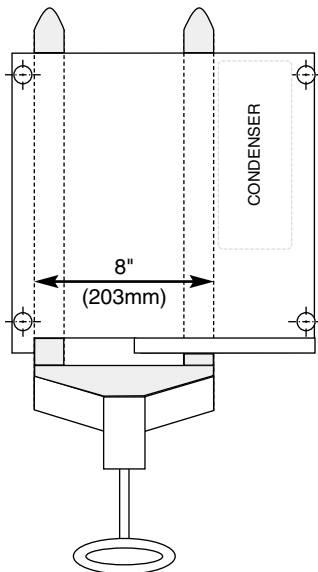

MODEL	NET WEIGHT
6•05	180 lb (82 kg)
6•10iN	285 lb (129 kg)
10•10iN	385 lb (175 kg)
7•14i	405 lb (184 kg)

After the oven is correctly positioned on site, reattach the drip tray.



WARNING

FAILURE TO PROPERLY INSTALL THE DRIP TRAY CAN OR WILL CAUSE MAJOR EQUIPMENT DAMAGE AND WILL RESULT IN A LEAKAGE HAZARD THAT CAN CAUSE PERSONAL INJURY.

INSTALLATION REQUIREMENTS

- Do not install oven adjacent to flammable surfaces. Strictly observe all local fire safety regulations.
- In order to ensure proper ventilation, a minimum distance of at least 6-inches (152mm) must be kept from the control panel side [LEFT] of the oven and any adjoining surfaces.

NOTE: In addition to ventilation requirements, additional clearance is needed for service access. A minimum distance of 18-inches (457mm) is strongly recommended. If adequate service clearance is not provided, it will be necessary to disconnect the gas, water, and drain to move the oven with a fork lift for service access. Charges in connection with inadequate service access is not covered under warranty.

- Allow a minimum of 4-inches (102mm) from the right side of the oven to allow the door to open to at least a 90° angle. Fully opened, the door will extend up to a 225° angle. If the oven is furnished with the retractable door option, allow a minimum clearance of 6-1/2-inches (16cm).
- Allow a minimum clearance of 4-inches (102mm) from the back of the oven for plumbing connections.
- Allow a 20-inch (50cm) clearance at the top of the oven for free air movement and for the steam vent(s) located at the top [RIGHT-REAR].
- Do not install the oven adjacent to heat producing equipment such as fryers, broilers, etc. Minimum clearance recommended: 20-inches (50cm).

Place the Combitherm oven on a stable, non-combustible **LEVEL** horizontal surface. For counter-top models, the oven stand must be level. In addition, the overall height of the oven should be positioned so the operating controls and shelves may be conveniently reached from the front.

ALL INSTALLATION INSTRUCTIONS AND REQUIREMENTS MUST BE STRICTLY OBSERVED.



IMPROPER CONNECTION OF THIS APPLIANCE NULLIFIES ALL WARRANTIES.

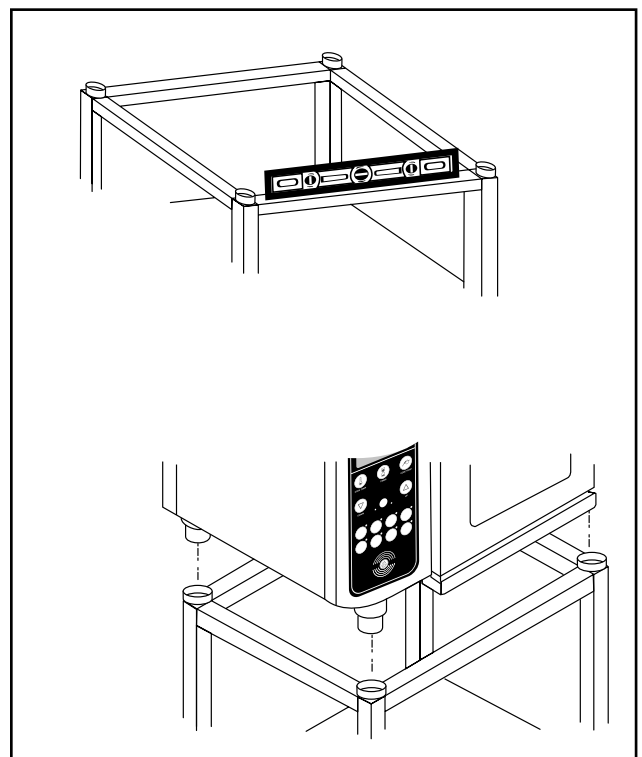
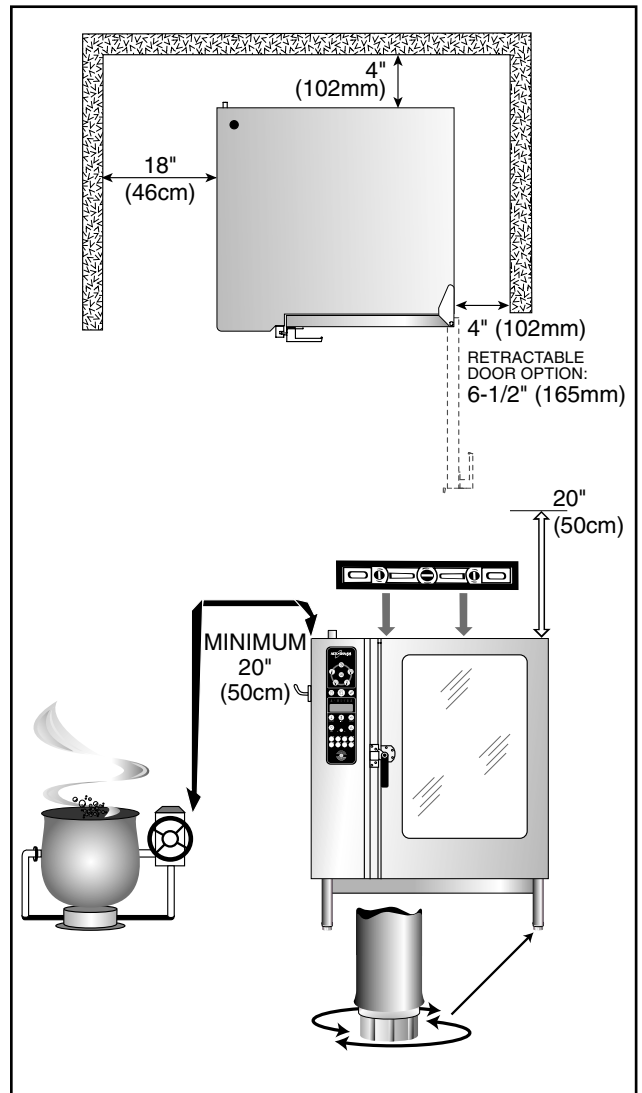

COMBITHERM® INSTALLATION

ASSEMBLY REQUIREMENTS

HAND SHOWER HOLDER

Fasten the hand shower holder in the holes provided on the oven using the three (3) screws packaged with the holder.

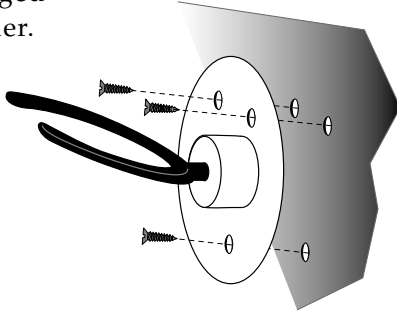

DRIP TRAY INSTALLATION

Hang the drip tray at the front of the oven as indicated on the drawing.

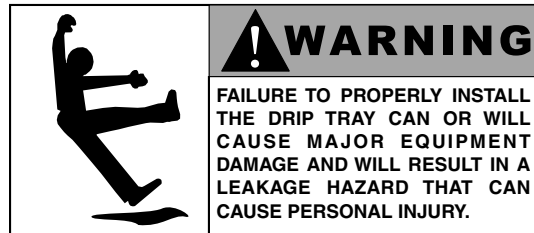
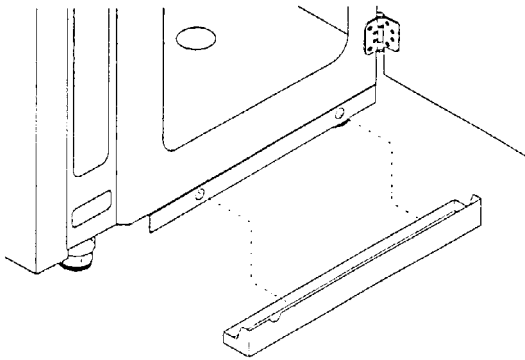

! WARNING

FAILURE TO PROPERLY INSTALL THE DRIP TRAY CAN OR WILL CAUSE MAJOR EQUIPMENT DAMAGE AND WILL RESULT IN A LEAKAGE HAZARD THAT CAN CAUSE PERSONAL INJURY.



DANGER

IMPROPER INSTALLATION, ALTERATION, ADJUSTMENT, SERVICE OR MAINTENANCE COULD RESULT IN SEVERE INJURY, DEATH OR CAUSE PROPERTY DAMAGE.

COMBITHERM® INSTALLATION

WATER SUPPLY

CONNECT TO POTABLE (DRINKABLE) COLD WATER ONLY

A water conditioning system is recommended if the water supply is between 5 and 9 grains of hardness. If water tests over 9 grains of hardness, the installation of a water softener is strongly recommended. **Without treated water and the use of Alto-Shaam's CombiGuard™, the operation life of the unit will be diminished and affect the warranty.**

WATER	
COLD WATER INLET — DRINKING QUALITY	
INDIRECT WASTE PIPE WITH AIR GAP: 1-1/4" NPT	
INLET: 3/4" NPT	LINE PRESSURE: 30 to 90 psi 2.8 to 6.2 bar
CHLORINE: less than 0.8 ppm	CHLORIDE: less than 70 ppm
HARDNESS: 5 to 9 gpg 85 to 154 ppm	PH RANGE: 7.0 to 9.0
WATER SOFTENER SHOULD BE UTILIZED IN HARD WATER AREAS.	
WATER OUTLET: 1-1/4" (33mm) DRAIN WITH AIR GAP	

Flush the water line at the installation site before connecting the oven to the water supply. A shut-off valve and approved back-flow preventer must be installed when connecting the oven to the cold water intake. The water supply line must be a minimum of 3/4-inch NPT (19mm). Install the line filter at the cold water intake connection point.

PIPE SEALING TAPE (TEFLON®) MUST BE USED AT ALL CONNECTION POINTS.

The use of a pipe sealing compound is not recommended.

THE MAIN WATER SHUT-OFF VALVE MUST BE IN THE OPEN POSITION WHEN THE OVEN IS BEING USED.

The hand shower spray hose is installed adjacent to the cold water intake connection. A ball valve is installed on the oven for hose connection to the **COLD** water source. Assemble the washer and the flexible hose on the ball valve and hang the spray handle on the holder previously installed on the oven.

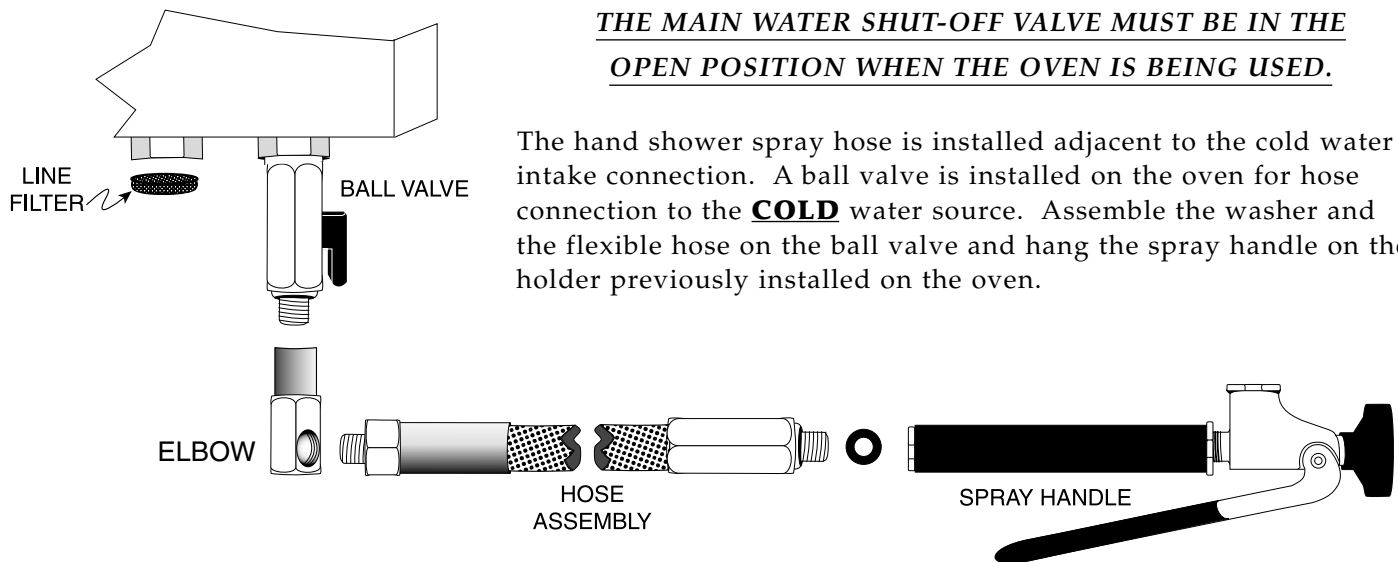



WARNING

TO PREVENT WATER PIPES OR HOSES FROM BURSTING, INCOMING WATER SUPPLY SHOULD BE TURNED OFF WHEN THE APPLIANCE IS NOT IN USE.



WARNING

WATER SUPPLY MUST BE OPEN WHEN CLEANING PROGRAM IS ACTIVATED.

VERIFY WATER SUPPLY BEFORE STARTING CLEANING PROGRAM.

COMBITHERM® INSTALLATION

WATER DRAINAGE

The oven must discharge through an indirect waste pipe by means of an air gap. The drain thread is 1-1/4-inch (32mm) NPT.

A union is required. Install a 1-1/4-inch (32mm) diameter drain line. The drain line must always be a positive gradient away from the Combitherm oven and not more than 12-inches (305mm) before an air gap.

NOTE: In the U.S.A., this equipment is to be installed to comply with the Basic Plumbing Code of the Building Officials and Code Administrators International, Inc. [BOCA], and the Food Service Sanitation Manual of the Food & Drug Administration [FDA].

If several units are to be connected to one drain pipe, the dimensions of the pipe must be sufficient to allow an unobstructed water drain system.

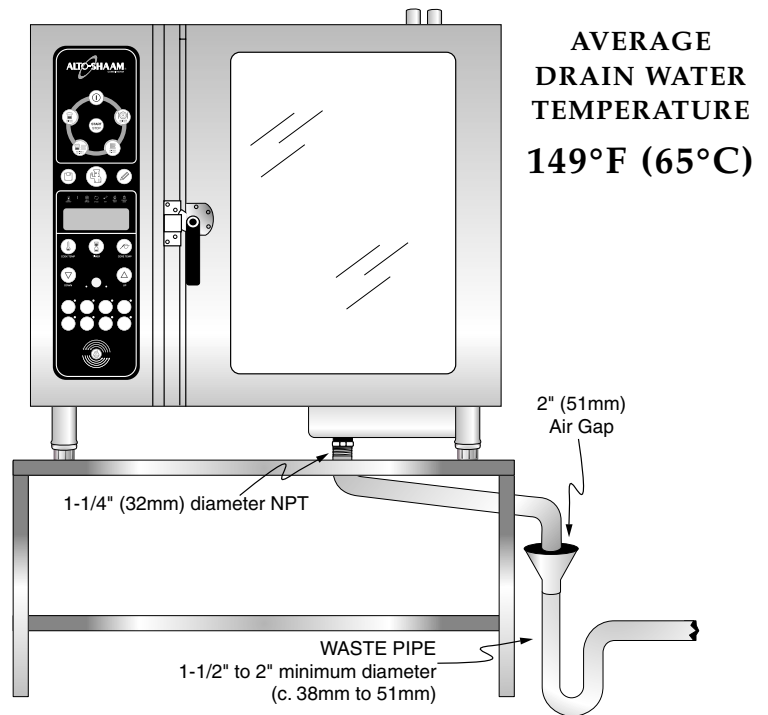

ADDITIONAL TECHNICAL DATA

MODEL ⇨	6•05ML	6•10-iNML	10•10iN	7•14i
Type of Oven	counter oven stand	counter oven stand	counter oven stand	counter oven stand
Pan Capacity INCHES	6: 12" x 10" 12: 12" x 6"	6: 12" x 20" 6: 18" x 13" 12: 12" x 10"	10: 12" x 20" 10: 18" x 13"	14: 12" x 20" 7: 18" x 26"
GASTRONORM	6: GN 1/2 12: GN 1/3	6: GN 1/1 18: GN 1/3	10: GN 1/1	14: GN 1/1
Side Rack Spacing INCHES (MILLIMETERS)	2-5/8 (65mm)	2-5/8 (65mm)	2-5/8 (65mm)	2-5/8 (65mm)
Interior Width INCHES (MILLIMETERS)	15-1/4 (596)	13-1/4 (387)	13-1/4 (387)	23-1/2 (596)
Interior Depth INCHES (MILLIMETERS)	17-7/8 (455)	26-1/4 (665)	26-1/4 (665)	28-7/16 (722)
Interior Height INCHES (MILLIMETERS)	17-3/4 (450)	17-3/4 (450)	27 (685)	20-5/16 (515)
Noise Level	The noise emission level related to the workplace is lower than: 70 dBA			
Spray Hose Length	81-inches (2050mm)	81-inches (2050mm)	81-inches (2050mm)	81-inches (2050mm)
Water Consumption (APPROX.)	3 - 5 gal/hr (12 - 20 l/hr)	4 - 6 gal/hr (15 - 25 l/hr)		

COMBITHERM® INSTALLATION

ELECTRICAL INSTALLATION



An electrical wiring diagram is located behind the control panel on the left side of the oven. The oven must be installed by a qualified electrician. This appliance must be branch circuit protected with proper ampacities, in accordance with the wiring diagram located in the electrical compartment of the oven. The oven must be properly grounded in accordance with the National Electrical Code and applicable local codes.

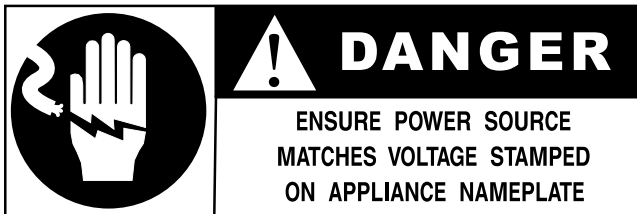

Wire size for the main incoming power to the unit must match the minimum size listed in the specifications applicable to the specific oven model. For supply connections, locate the wire size posted on the label located on the electrical control box cover, behind the service panel or elsewhere listed in this manual.

When connecting to a Delta-B (wild leg) on a 3-phase system, the wild leg must be connected to line 3.

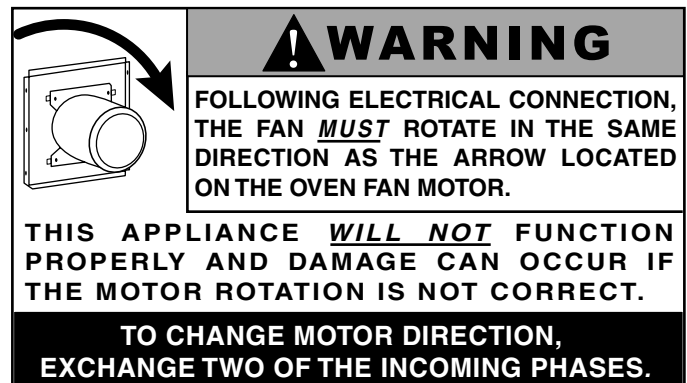
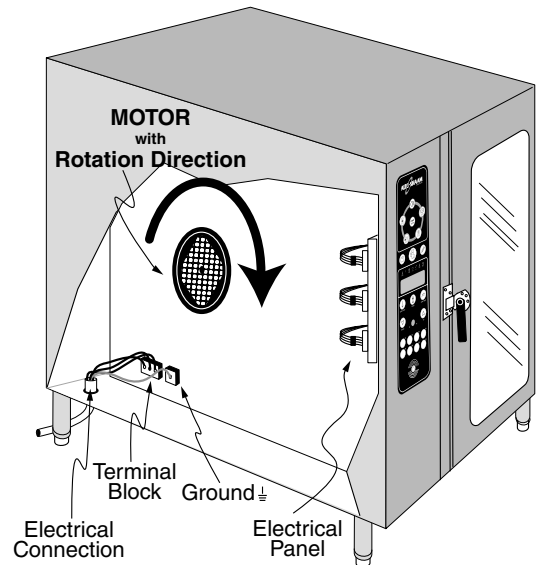
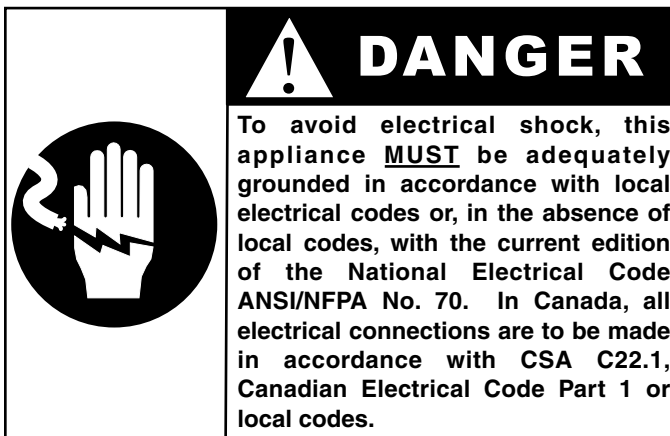

Before operating the oven, check all cable connections in the electrical connection area for tightness since connections can loosen during transport.

NOTE: After both water and electrical connections have been completed, operate the oven in any cooking mode for a period of 15 minutes and recheck the main power connections at the terminal block to make certain they remain tight.

COMBITHERM® INSTALLATION

STACKING INSTALLATION

Stacking Combitherm ovens require two (2) water connections, two (2) drain connections, and two (2) electrical connections.

If local code allows,

the water and drain may be manifolded as long as the size of the water inlet is increased to 1-inch (25,4mm) and the drains include an external vent. The drawing illustrates one suggested method of a manifold installation.

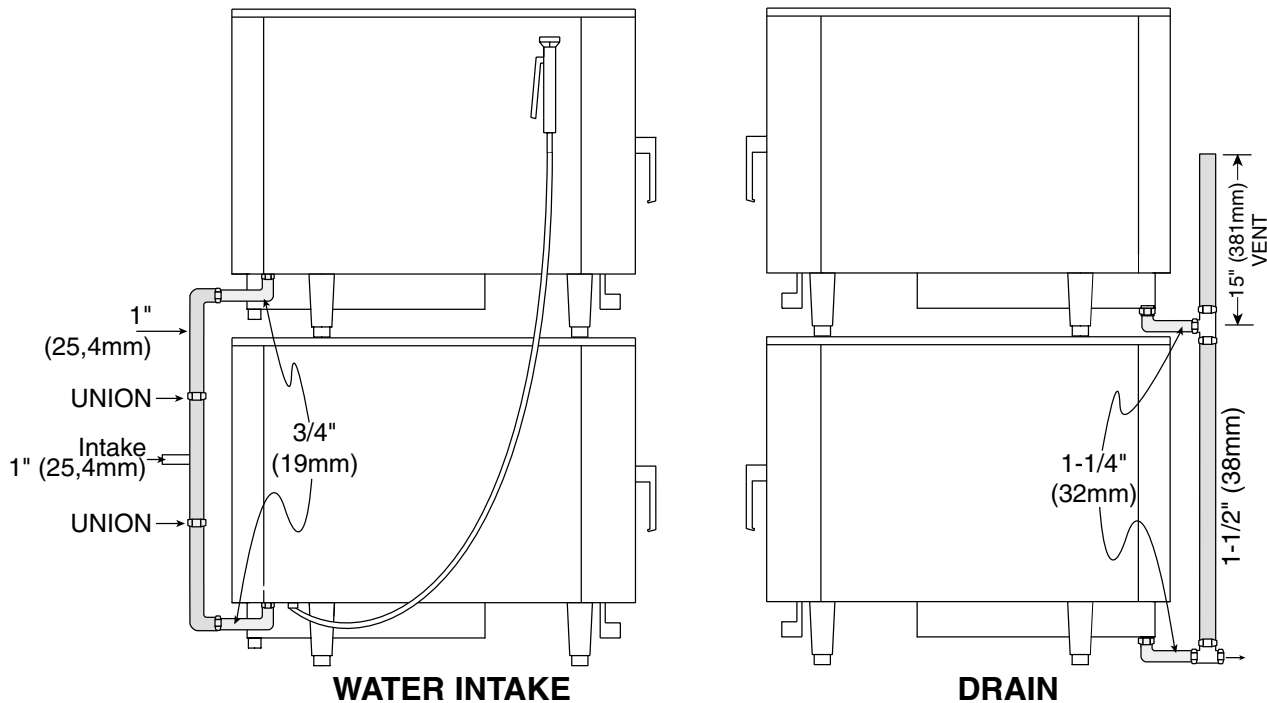

RESTRAINT REQUIREMENTS — MOBILE EQUIPMENT

Any appliance that is not furnished with a power supply cord but that includes a set of casters must be provided with a tether. Adequate means must be provided to limit the movement of this appliance without depending on or transmitting stress to the electrical conduit. The following requirements apply:

1. Casters must be a maximum height of 6" (152mm).
2. Two of the casters must be the locking type.
3. Such mobile appliances or appliances on mobile stands must be installed with the use of a flexible connector secured to the building structure.

A mounting connector for a restraining device is located on the lower back flange of the appliance chassis or on an oven stand, approximately 18" (457mm) from the floor. A flexible connector is not supplied by nor available from the factory.

	! WARNING
	RISK OF ELECTRIC SHOCK. Appliance must be secured to building structure.

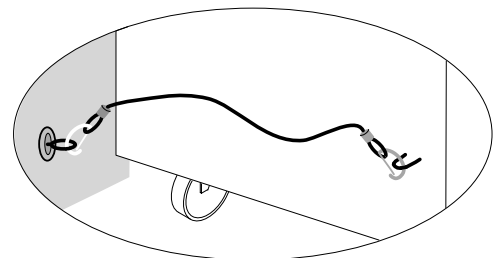



ELECTRIC COMBITHERM INSTALLATION CHECKLIST

Use this list as a final check of oven installation conformance. Damage directly attributed to improper set up, installation, or cleaning can invalidate warranty claims.

CLEARANCES: All clearances must conform with the standards set by Alto-Shaam as indicated in the installation manual. Standards include a minimum 20" (50cm) clearance from any heat-producing device such as an open burner range, flat top grille, fryer, steamer, etc. Also make sure sufficient service access is provided on the left side of the oven. There must be an allowance of free air access to all vents.

RIGHT SIDE CLEARANCE: _____
LEFT SIDE CLEARANCE: _____
REAR CLEARANCE: _____
UPPER CLEARANCE: _____

WATER SUPPLY AND DRAINS: Verify hook-up to *cold* water supply with a 3/4" (19mm) single water connection supply line. Verify inlet water pressure is at a minimum of 30 PSI (2 bar) for electric ovens. Maximum pressure is not to exceed 90 PSI (6 bar). Verify the installation of a water filter and the installation of a water conditioner if water supply is over 10 grains of hardness. Verify drain diameter of 1-1/4" (32mm) with a positive descending slope, and with a 2" (51mm) air gap which is free of obstructions before connection to the site drain. Verify 1/8" (3,2mm) pitch to 10' (305cm) of drain line. After pressure is adjusted, seal screw with enamel such as nail polish.

WATER SUPPLY LINE DIA: _____
COLD WATER: YES NO
WATER INLET PRESSURE: _____
DRAIN LINE DIA: _____
2" (51mm) AIR GAP: YES NO

ELECTRICAL CONNECTIONS: Verify electrical power requirements for oven. Verify voltage at terminal block. Verify correct power cable size. Verify equipment disconnect per NEC or applicable local codes. Motor direction should correspond with the direction of the arrow on the motor. Verify clockwise motor rotation from the rear of the motor. Check all terminals for tightness.

VOLTAGE: _____ **PHASE:** _____
LINE VOLTAGE AT TERMINAL BLOCK (TO GROUND):
 ▶ **LINE 1:** _____ **LINE 2:** _____ **LINE 3:** _____
LINE VOLTAGE (PHASE TO PHASE): **LINE 1 to 2:** _____
LINE 2 to 3: _____
LINE 3 to 1: _____
ELECTRICAL SUPPLY LINE SIZE: _____
CORRECT MOTOR ROTATION: YES NO
ALL ELECTRICAL TERMINALS TIGHT: YES NO

CONTROL BOARD CONNECTIONS & OPERATION: Verify all control board connections are tight including tightness and proper connection of ribbon/computer cables. Verify all buttons and lights illuminate. With the Power Key OFF, press and hold the Chef Function Key to access software version, and record. Verify all functions operate.

ALL BOARD CONNECTIONS TIGHT: YES NO
ALL FUNCTIONS LIGHT UP: YES NO
ALL FUNCTIONS OPERATE: YES NO
SOFTWARE VERSION:
 BM _____ SM _____ KM _____

PHYSICAL CONDITION:

Bottom of oven has been checked for damage due to improper positioning on site ✓
 Verify all gaskets, hoses, and carts are in place and function properly
 If oven includes a cart, verify proper installation of the rack guide
 Verify the installation of drip pans, racks, shelves, drain screen, spray hose
 Verify the oven is level and installed on a solid, water resistant floor

SERVICE AGENCY: _____ **START-UP DATE:** _____
 _____ **INSTALLATION NAME:** _____
TECH _____ **CUSTOMER** _____
SIGNATURE: _____ **SIGNATURE:** _____

CONTROL PANEL IDENTIFICATION

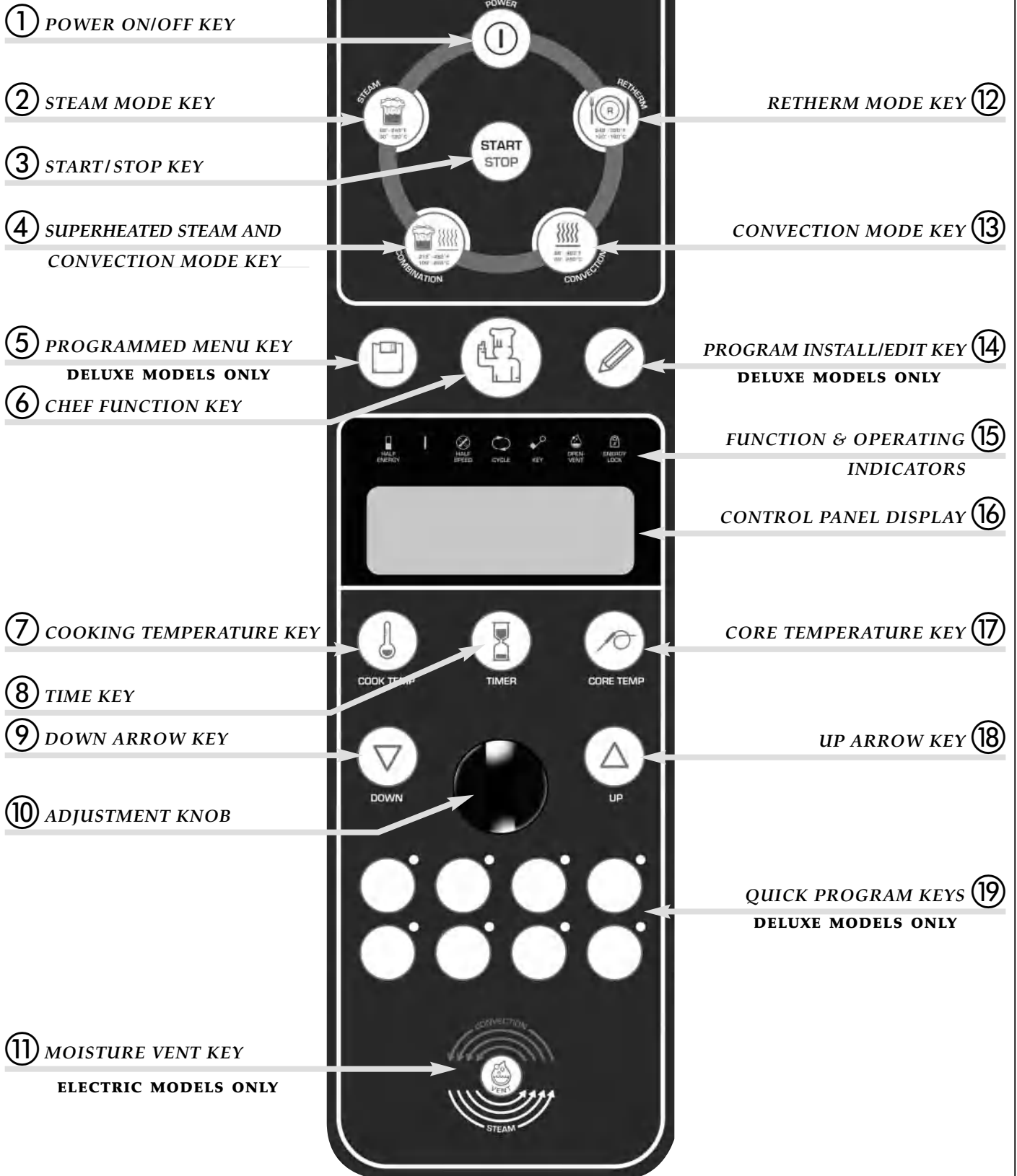

CONTROL PANEL IDENTIFICATION

- ① **POWER ON/OFF KEY**
Activates power to the oven.
- ② **STEAM MODE KEY**
The oven will operate in the steam mode at a temperature range of 86°F to 248°F (30°C to 120°C).
- Automatic steaming at 212°F (100°C) **FACTORY-SET DEFAULT.**
 - Quick steaming between 213°F and 248°F (101°C and 120°C).
 - Low Temperature Steaming between 86°F and 211°F (30°C and 99°C).
- ③ **START/STOP KEY**
Initiates all cooking mode functions and programmed procedures stored in memory. Stops an activated cooking mode or programmed procedure currently in progress, and exits Chef function key.
- ④ **SUPERHEATED STEAM AND CONVECTION MODE KEY**
Selection key for the combination steam and convection cooking mode which can be set within a temperature range of 212°F to 482°F (100°C and 250°C).
- ⑤ **PROGRAMMED MENU KEY**
Shows a list menu in display ⑯ of all stored cooking programs and is also used to exit the list menu display. **DELUXE MODELS ONLY.**
- ⑥ **CHEF FUNCTION KEY**
Used to select programmed menu functions, various auxiliary functions, and several chef help instructions.
- ⑦ **COOKING TEMPERATURE KEY**
Used to set the required cooking temperature, to recall the set cooking temperature, or to check the actual oven temperature in conjunction with the down arrow key ⑨, the up arrow key ⑱ or the adjustment knob ⑩.
- ⑧ **TIME KEY**
Used to set the required cooking time or recall the set cooking time in conjunction with the down arrow key ⑨, the up arrow key ⑱ or the adjustment knob ⑩.
- ⑨ **DOWN ARROW KEY**
Used to decrease displayed cook temperature ⑦, time ⑧, or core temperature ⑰ and as a scrolling key for programming functions.

- ⑩ **ADJUSTMENT KNOB**
Serves the same function as the up and down arrow keys to increase or decrease the displayed cook temperature ⑦, time ⑧, or core temperature ⑰.
- ⑪ **MOISTURE VENT KEY** **ELECTRIC MODELS ONLY**
Immediately vents steam and condensate from the oven compartment while cooking in the Convection mode ⑬ or in the Superheated Steam and Convection mode ④.
- ⑫ **RETHERM MODE KEY**
Food rethermalization or reheating mode will operate with automatic steam injection at a temperature range of 248°F and 320°F (120°C and 160°C).
- ⑬ **CONVECTION MODE KEY**
Selection key for convection cooking without steam at a temperature range of 86°F to 482°F (30°C and 250°C).
- ⑭ **PROGRAM INSTALL AND EDIT KEY**
Used to create, change, duplicate, and delete programmed menus. **DELUXE MODELS ONLY.**

⑮ FUNCTION & OPERATING INDICATORS

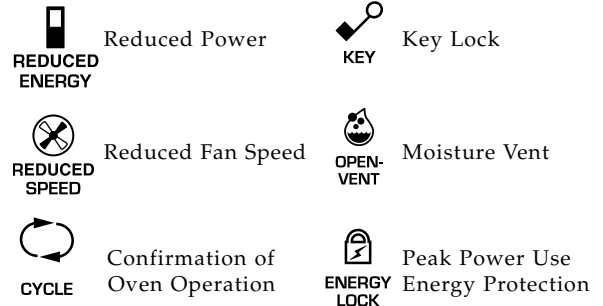

⑯ CONTROL PANEL DISPLAY

- ⑰ **CORE TEMPERATURE KEY**
Used to set the required internal product temperature, to recall the internal product temperature set by the operator, or to display the current internal temperature of the product in conjunction with the down arrow key ⑨, the up arrow key ⑱ or the adjustment knob ⑩.
- ⑱ **UP ARROW KEY**
Used to increase displayed cook temperature ⑦, time ⑧, or core temperature ⑰ and as a scrolling key for programming functions.
- ⑲ **QUICK PROGRAM KEYS**
Immediate access to frequently used operator set programs including cooking modes, cleaning, and other oven functions. **DELUXE MODELS ONLY.**

S-CONTROL PANEL IDENTIFICATION



① OFF POSITION

Maintains oven in a stand-by mode.

② STEAM

The oven will operate at a fixed steam temperature of 212° F (100°C).

③ COMBINATION

A combination of steam and convection heat to cook at a temperature between 86°F and 482°F (30°C to 250°C) to be set by the operator.

④ CONVECTION

Convection heat to cook without steam at a temperature between 86°F and 482°F (30°C and 250°C) to be set by the operator.

⑤ LOW STEAM

Low temperature steaming within an operator set temperature range of 86°F to 210°F (30°C and 99°C).

⑥ CLEANING FUNCTION

An automatic cleaning cycle to heat the oven to the correct temperature, followed by a manual application of Combitherm Liquid Oven Cleaner and a 10 minute steam cleaning cycle. An automatic boiler flush is initiated on boiler equipped models and a vinegar decalcification can also be conducted.

⑦ COOKING TEMPERATURE DIAL

To be manually set by the operator to the cooking temperature required.

⑧ OVEN DISPLAY

Indicates time remaining or interior oven temperature.

⑨ COOKING TIMER

- ⊖ Turned to the left for continuous cooking time or to decrease time in increments of one minute.
- ⊕ Turn to the right to set and increase time in increments of one minute.

⑩ OVEN TEMPERATURE

To be pressed to display interior oven temperature.

⑪ FULL SPEED FAN POSITION

⑫ HALF SPEED FAN POSITION

⑬ OVEN COOL-DOWN POSITION

Assists in cooling the oven at an accelerated pace when changing from high to lower temperature cooking. **The oven door should be open when using this feature.**

SMOKER CONTROL PANEL IDENTIFICATION STANDARD AND PROGRAMMABLE DELUXE MODELS

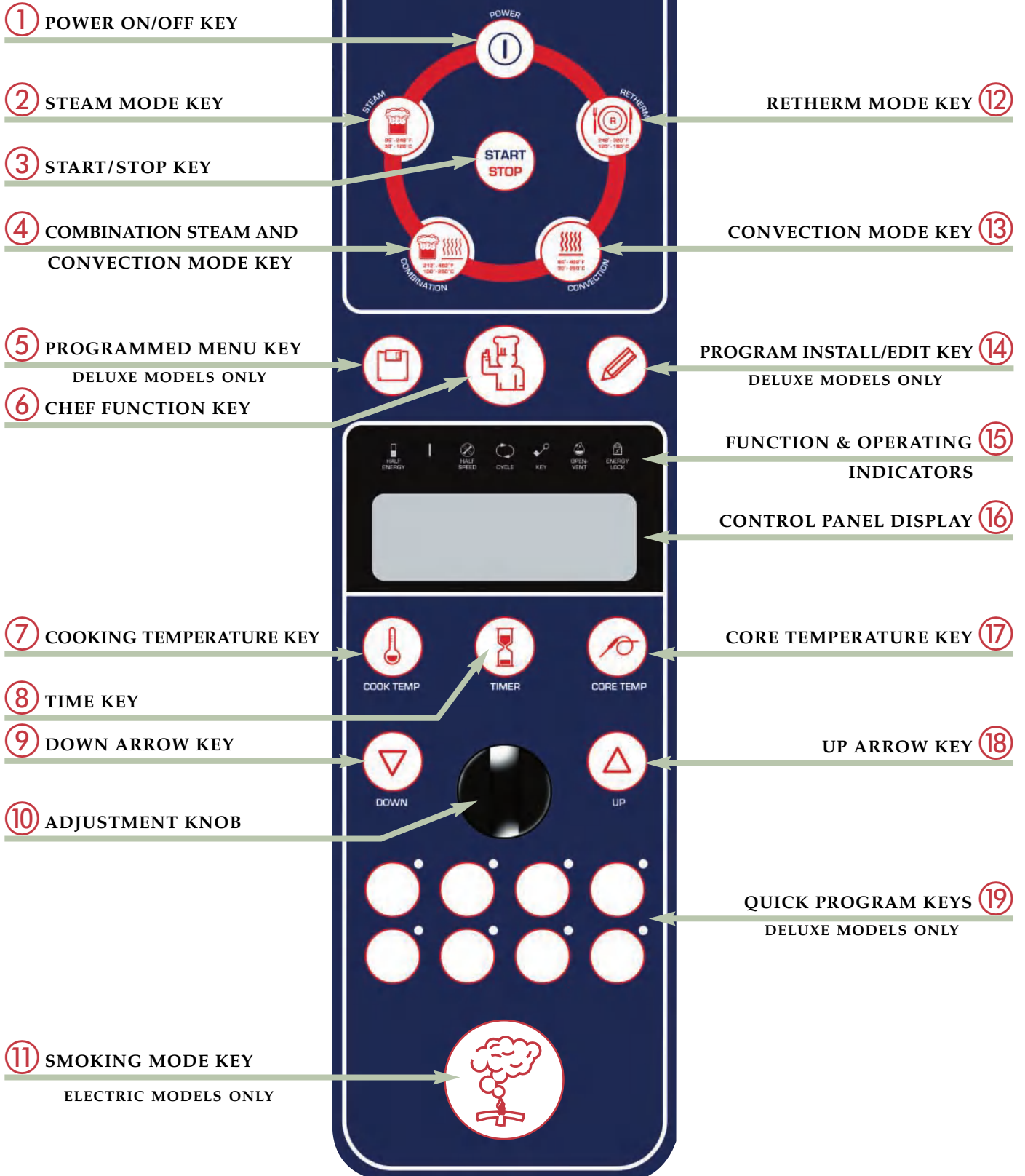

SMOKER CONTROL PANEL BASIC FUNCTION

1 POWER ON/OFF KEY
 Activates power to the oven and automatically fills the steam generator with water which will heat to a stand-by mode temperature of 150°F (65°C). The steam generator flush is also activated by pressing this key.

2 STEAM MODE KEY
 The oven will operate in the steam mode at a temperature range of 86°F to 248°F (30°C to 120°C).

- Automatic steaming at 212°F (100°C) FACTORY-SET DEFAULT.
- Quick steaming between 213°F and 248°F (101°C and 120°C).
- Low Temperature Steaming between 86°F and 211°F (30°C and 99°C).

3 START/STOP KEY
 Initiates all cooking mode functions and programmed procedures stored in memory. Stops an activated cooking mode or programmed procedure currently in progress, and exits Chef function key.

4 SUPERHEATED STEAM AND CONVECTION MODE KEY
 Selection key for the combination steam and convection cooking mode which can be set within a temperature range of 212°F to 482°F (100°C and 250°C).

5 PROGRAMMED MENU KEY
 Used to access and exit a menu list of all stored cooking programs which can be reviewed in display **16**. DELUXE MODELS ONLY

6 CHEF FUNCTION KEY
 Used to select programmed menu functions, various auxiliary functions, and several chef help instructions.

7 COOKING TEMPERATURE KEY
 Used to set the required cooking temperature, to recall the set cooking temperature, or to check the actual oven temperature in conjunction with the down arrow key **9**, the up arrow key **18** or the adjustment knob **10**.

8 TIME KEY
 Used to set the required cooking time or recall the set cooking time in conjunction with the down arrow key **9**, the up arrow key **18**, or the adjustment knob **10**.

9 DOWN ARROW KEY
 Used to decrease displayed cook temperature **7**, time **8**, or core temperature **17** and as a scrolling key for programming functions.

10 ADJUSTMENT KNOB
 Serves the same function as the up and down arrow keys to increase or decrease the displayed cook temperature **7**, time **8**, or core temperature **17**.

11 SMOKING MODE KEY ELECTRIC MODELS ONLY
 Initiates the production of smoke from the wood chip container located at the bottom of the oven compartment. The smoking function operates in the convection mode and in the combination mode.

12 RETHERM MODE KEY
 Food rethermalization or reheating mode will operate with automatic steam injection at a temperature range of 248°F and 320°F (30°C and 250°C).

13 CONVECTION MODE KEY
 Selection key for convection cooking without steam at a temperature range of 86°F to 482°F (30°C and 250°C).

14 PROGRAM INSTALL AND EDIT KEY
 Used to create, change, duplicate, and delete programmed menus. DELUXE MODELS ONLY.

15 FUNCTION & OPERATING INDICATORS

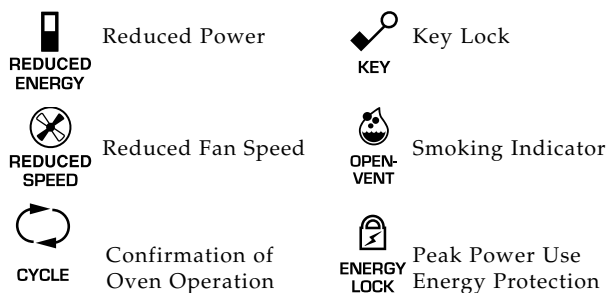

16 CONTROL PANEL DISPLAY

17 CORE TEMPERATURE KEY
 Used to set the required internal product temperature, to recall the internal product temperature set by the operator, or to display the current internal temperature of the product in conjunction with the down arrow key **9**, the up arrow key **18**, or the adjustment knob **10**.

18 UP ARROW KEY
 Used to increase displayed cook temperature **7**, time **8**, or core temperature **17** and as a scrolling key for programming functions.

19 QUICK PROGRAM KEYS
 Immediate access to frequently used operator set programs including cooking modes, cleaning, and other oven functions. DELUXE MODELS ONLY.

COMBITHERM SMOKER OPERATION

GENERAL OPERATION — SMOKERS

Load wood chips.

- Measure one container full of dry wood chips.
- Soak dry chips in water for 5 minutes.
- Shake excess water off wood chips.
- Place moistened chips back into the container and position the container in the holder located on the interior back panel of the smoker.

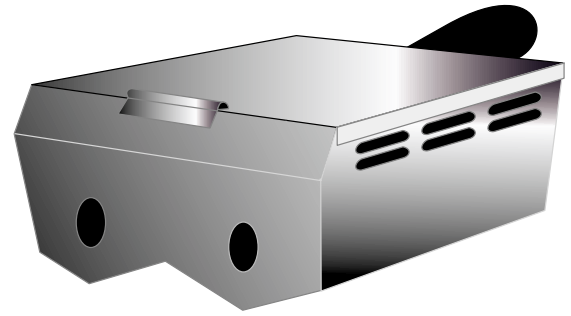





WARNING

THE USE OF IMPROPER MATERIALS FOR THE SMOKING FUNCTION COULD RESULT IN DAMAGE, HAZARD, EQUIPMENT FAILURE OR COULD REDUCE THE OVERALL LIFE OF THE OVEN. DO NOT USE SAWDUST FOR SMOKING. DO NOT USE WOOD CHIPS SMALLER THAN THUMBNAIL SIZE.



The smoking function can be used whenever the oven is operating in the convection mode or the combination mode. The smoking function cannot be operated when the oven is operating in steam mode or the retherm mode.

The smoking function can be programmed into a procedure with any of the Duluxe Combitherm Smoker models. Press the smoking function  button after setting time  or core temperature  in the Convection mode  or the Combination mode .

A full container of wood chips will produce smoke for an approximate period of one hour. This time period will vary depending on the degree of cooking temperature used, however, by following the tested procedures set fourth in this manual, smoke production will be more than sufficient for complete product smoke penetration and full smoke flavor. Other procedures in the front portion of this manual can be adapted to a smoked product offering. If you need assistance, you are invited to contact an Alto-Shaam corporate chef for recommendations.



The Combitherm Smoker icon must be pushed again when the smoking function has been completed. This disengages the smoker elements.

The Combitherm Smoker can be operated without using the smoking function. After using the oven as a smoker, however, it is necessary to clean the oven in order to prevent a transfer of smoke flavor. Cleaning instructions are provided in a previous section of this manual.

AVAILABLE FROM ALTO-SHAAM

WOOD CHIPS	20 POUND BULK PACKS	
THE TOTAL WEIGHT OF WOOD CHIP BULK PACKS MAY VARY DUE TO HIGH MOISTURE CONTENT WHEN PACKAGED.	APPLE	WC-22543
	HICKORY	WC-2829
	CHERRY	WC-22541
	SUGAR MAPLE	WC-22545

PREHEAT THE OVEN BEFORE COOKING PRODUCT

COMBITHERM SMOKER OVEN PROCEDURE

PRODUCT

➤ Beef Brisket, Fresh: 9 to 13 lb (4 to 6 kg)

MATERIALS

➤ Stainless steel sheet pans or full-size pans
 Wire pan grids (optional)
 Vegetable release spray (optional)
 Seasoning

PRODUCT PREPARATION

➤ Spray pans or wire pan grids with vegetable release spray if desired.

Place briskets in pans and season as desired.

Load pans in preheated oven.



FAN SPEED Full Speed



WOOD CHIP CONTAINER Full

PRESS & SET EACH OPERATING FUNCTION IN SEQUENCE

1.	2.	3.
 OVEN MODE Steam Mode	 OVEN MODE Convection Mode	 OVEN MODE Combination Mode
 COOKING TEMPERATURE 180°F (82°C)	 COOKING TEMPERATURE 90°F (32°C)	 COOKING TEMPERATURE 225°F (107°C)
 TIMER APPROXIMATE COOK TIME 10 minutes	 TIMER APPROXIMATE COOK TIME 30 minutes	 TIMER APPROXIMATE COOK TIME 3 hours
 SMOKING FUNCTION DO NOT PRESS	 SMOKING FUNCTION Press to engage smoke	 SMOKING FUNCTION Press to engage smoke

USE APPROXIMATE COOKING TIMES SHOWN FOR FULL OR PARTIAL LOADS

PRESS START



MAXIMUM CAPACITY

MODEL 6•10iN/SK	MODEL 10•10iN/SK	MODEL 7•14i/SK
5 full-size pans (GN 1/1)	9 full-size pans (GN 1/1)	12 full-size pans (GN 1/1)

PAN SIZES

FINAL INTERNAL PRODUCT TEMPERATURE

PAN SIZES

➤ Full-size Pans: 20" x 12" x 2-1/2"
 Half-size Sheet Pans: 18" x 13" x 1"
 (GN 1/1: 530mm x 325mm x 20mm)

165°F (73°C)

STOP THE COOKING FUNCTION AT ANY TIME BY PRESSING THE STOP KEY.

Time and temperature settings are suggested guidelines only. Due to variations in product quality, weight, and desired degree of doneness the controls may require some adjustment from the time and temperatures shown. All cooking should be based on internal product temperatures.



BEEF RIBS

PREHEAT THE OVEN BEFORE COOKING PRODUCT

COMBITHERM SMOKER OVEN PROCEDURE

PRODUCT

➤ Beef Ribs: 2 to 3 lb (1 to 1,3 kg)

MATERIALS

➤ Stainless steel or aluminum sheet pans or full-size pans
Vegetable release spray (optional)
Seasoning

PRODUCT PREPARATION

➤ Spray pans with vegetable release spray if desired.

Place short ribs side-by-side in pans and season as desired.

Load pans in preheated oven.



FAN SPEED Full Speed



WOOD CHIP CONTAINER Full

PRESS & SET EACH OPERATING FUNCTION IN SEQUENCE

1.	2.	3.
<p>OVEN MODE Steam Mode</p>	<p>OVEN MODE Convection Mode</p>	<p>OVEN MODE Combination Mode</p>
<p>COOKING TEMPERATURE 180°F (82°C)</p>	<p>COOKING TEMPERATURE 90°F (32°C)</p>	<p>COOKING TEMPERATURE 225°F (107°C)</p>
<p>TIMER APPROXIMATE COOK TIME 10 minutes</p>	<p>TIMER APPROXIMATE COOK TIME 30 minutes</p>	<p>TIMER APPROXIMATE COOK TIME 2 hours</p>
<p>SMOKING FUNCTION DO NOT PRESS</p>	<p>SMOKING FUNCTION Press to engage smoke</p>	<p>SMOKING FUNCTION Press to engage smoke</p>

USE APPROXIMATE COOKING TIMES SHOWN FOR FULL OR PARTIAL LOADS

PRESS START

START STOP

MAXIMUM CAPACITY

MODEL 6•10iN/SK
5 full-size pans
(GN 1/1)

MODEL 10•10iN/SK
9 full-size pans
(GN 1/1)

MODEL 7•14i/SK
12 full-size pans
(GN 1/1)

PAN SIZES

FINAL INTERNAL PRODUCT TEMPERATURE

PAN SIZES

➤ Full-size Pans: 20" x 12" x 2-1/2"
Half-size Sheet Pans: 18" x 13" x 1"
(GN 1/1: 530mm x 325mm x 20mm)

190°F (88°C)

STOP THE COOKING FUNCTION AT ANY TIME BY PRESSING THE STOP KEY.



PREHEAT THE OVEN BEFORE COOKING PRODUCT

COMBITHERM SMOKER OVEN PROCEDURE

PRODUCT
➤ Pork back ribs:
1-3/4 down

MATERIALS
➤ Stainless steel or aluminum sheet pans or full-size pans
Seasoning
Barbeque Sauce (optional)

PRODUCT PREPARATION
➤ Place ribs side-by side on pans and season as desired.
Load pans in preheated oven.

NOTE: When cooking for immediate service or hot food holding, brush with heated barbeque sauce **after** ribs are removed from the oven to prevent sauce from burning. As an alternative, ribs can be cooked in advance, rapidly chilled, and removed from refrigeration for reheating and service as required. Barbecue sauce can be used for the reheating process.



FAN SPEED Full Speed



WOOD CHIP CONTAINER Full

PRESS & SET EACH OPERATING FUNCTION IN SEQUENCE

1.	2.	3.
 OVEN MODE Steam Mode	 OVEN MODE Convection Mode	 OVEN MODE Combination Mode
 COOKING TEMPERATURE 160°F (71°C)	 COOKING TEMPERATURE 90°F (32°C)	 COOKING TEMPERATURE 225°F (107°C)
 TIMER APPROXIMATE COOK TIME 10 minutes	 TIMER APPROXIMATE COOK TIME 30 minutes	 TIMER APPROXIMATE COOK TIME 50 minutes
 SMOKING FUNCTION DO NOT PRESS	 SMOKING FUNCTION Press to engage smoke	 SMOKING FUNCTION Press to engage smoke

USE APPROXIMATE COOKING TIMES SHOWN FOR FULL OR PARTIAL LOADS

PRESS START

START
STOP

MAXIMUM CAPACITY

MODEL 6•10iN/SK
5 full-size pans
(GN 1/1)

MODEL 10•10iN/SK
9 full-size pans
(GN 1/1)

MODEL 7•14i/SK
12 full-size pans
(GN 1/1)

PAN SIZES

PAN SIZES
➤ Full-size Pans: 20" x 12" x 2-1/2"
Half-size Sheet Pans: 18" x 13" x 1"
(GN 1/1: 530mm x 325mm x 20mm)

FINAL INTERNAL PRODUCT TEMPERATURE

175° to 180°F
(79° to 92°C)

STOP THE COOKING FUNCTION AT ANY TIME BY PRESSING THE STOP KEY.

START
STOP

PORK SHOULDER

PREHEAT THE OVEN BEFORE COOKING PRODUCT

COMBITHERM SMOKER OVEN PROCEDURE

PRODUCT

➤ Pork Shoulder, Boston Butt, Bone-In or Boneless: 8 to 10 lb (4 to 5 kg)

MATERIALS

➤ Stainless steel sheet pans or full-size pans
Vegetable release spray (optional)
Seasoning

PRODUCT PREPARATION

➤ Spray pans with vegetable release spray if desired.

Place briskets in pans and season as desired.

Load pans in preheated oven.















FAN SPEED Full Speed



WOOD CHIP CONTAINER Full

PRESS & SET EACH OPERATING FUNCTION IN SEQUENCE

1.	2.	3.
 <p>OVEN MODE Steam Mode</p>	 <p>OVEN MODE Convection Mode</p>	 <p>OVEN MODE Combination Mode</p>
 <p>COOKING TEMPERATURE 160°F (71°C)</p>	 <p>COOKING TEMPERATURE 90°F (32°C)</p>	 <p>COOKING TEMPERATURE 225°F (107°C)</p>
 <p>TIMER APPROXIMATE COOK TIME 10 minutes</p>	 <p>TIMER APPROXIMATE COOK TIME 30 minutes</p>	 <p>TIMER APPROXIMATE COOK TIME 2 hours, 30 minutes</p>
 <p>SMOKING FUNCTION DO NOT PRESS</p>	 <p>SMOKING FUNCTION Press to engage smoke</p>	 <p>SMOKING FUNCTION Press to engage smoke</p>

USE APPROXIMATE COOKING TIMES SHOWN FOR FULL OR PARTIAL LOADS

PRESS START

START STOP

MAXIMUM CAPACITY

MODEL 6•10iN/SK
5 full-size pans
(GN 1/1)

MODEL 10•10iN/SK
9 full-size pans
(GN 1/1)

MODEL 7•14i/SK
12 full-size pans
(GN 1/1)

PAN SIZES

FINAL INTERNAL PRODUCT TEMPERATURE

PAN SIZES

➤ Full-size Pans: 20" x 12" x 2-1/2"
Half-size Sheet Pans: 18" x 13" x 1"
(GN 1/1: 530mm x 325mm x 20mm)

165°F to 170°F
(74°C to 77°C)

STOP THE COOKING FUNCTION AT ANY TIME BY PRESSING THE STOP KEY.

START STOP

PREHEAT THE OVEN BEFORE COOKING PRODUCT

COMBITHERM SMOKER OVEN PROCEDURE

PRODUCT
➤ Chicken, Whole: 2-1/4 to 2-3/4 lb (1 to 1,2 kg) each

MATERIALS
➤ Seasoning
➤ Vegetable release spray
➤ Stainless steel or aluminum sheet pans with wire pan grids
➤ or Alto-Shaam chicken roasting racks with grease tray

PRODUCT PREPARATION
➤ Place chicken on sprayed, grid-lined sheet pans or on roasting racks.
➤ If desired, fold the wings and tuck under the back of the bird. Cross and secure legs.
➤ Season as desired.
➤ Load chicken in preheated oven.

NOTE: When using roasting racks, insert the grease tray before preheating or use rack with an attached grease tray. When using sheet pans, do not overload each pan. Chickens should not touch.



FAN SPEED Full Speed



WOOD CHIP CONTAINER Full

PRESS & SET EACH OPERATING FUNCTION IN SEQUENCE

1.	2.	3.
 OVEN MODE Steam Mode	 OVEN MODE Convection Mode	 OVEN MODE Combination Mode
 COOKING TEMPERATURE 160°F (71°C)	 COOKING TEMPERATURE 90°F (32°C)	 COOKING TEMPERATURE 225°F (107°C)
 TIMER APPROXIMATE COOK TIME 10 minutes	 TIMER APPROXIMATE COOK TIME 30 minutes	 TIMER APPROXIMATE COOK TIME 45 minutes
 SMOKING FUNCTION DO NOT PRESS	 SMOKING FUNCTION Press to engage smoke	 SMOKING FUNCTION Press to engage smoke

USE APPROXIMATE COOKING TIMES SHOWN FOR FULL OR PARTIAL LOADS

PRESS START



MAXIMUM CAPACITY

MODEL 6•10iN/SK
1 full-size pan
(GN 1/1)

MODEL 10•10iN/SK
2 full-size pans
(GN 1/1)

MODEL 7•14i/SK
4 full-size pans
(GN 1/1)

PAN SIZES

PAN SIZES
➤ Full-size Pans: 20" x 12" x 2-1/2"
➤ (GN 1/1: 530mm x 325mm x 20mm)

FINAL INTERNAL PRODUCT TEMPERATURE

175°F
(79°C)

STOP THE COOKING FUNCTION AT ANY TIME BY PRESSING THE STOP KEY.



TURKEY BREAST

— Fresh or Precooked, Boneless

PREHEAT THE OVEN BEFORE COOKING PRODUCT

COMBITHERM SMOKER OVEN PROCEDURE

PRODUCT

Turkey breast, boneless: Fresh (raw) or precooked, 8 lb (4 kg) each

MATERIALS

Stainless steel or aluminum sheet pans
Wire pan grids (optional)
Vegetable release spray (optional)
Seasoning

PRODUCT PREPARATION

Each breast should be relatively uniform in size to assure even heating and smoking from item to item. Place turkey breasts in pans and season as desired. Load pans in a preheated oven.

NOTE: When using CORE-TEMP mode, insert the probe so that the tip of the probe is centered in the breast. Approximate core temperature cut-off is 155° to 160°F (68° to 71°C).



FAN SPEED Half Speed



WOOD CHIP CONTAINER Full

PRESS & SET EACH OPERATING FUNCTION IN SEQUENCE

1.	2.	3.
 OVEN MODE Steam Mode	 OVEN MODE Convection Mode	 OVEN MODE Combination Mode
 COOKING TEMPERATURE 180°F (82°C)	 COOKING TEMPERATURE 90°F (32°C)	 COOKING TEMPERATURE 225°F (107°C)
 TIMER APPROXIMATE COOK TIME 30 minutes	 TIMER APPROXIMATE COOK TIME 30 minutes	 TIMER APPROXIMATE COOK TIME 1 hour, 45 minutes
 SMOKING FUNCTION DO NOT PRESS	 SMOKING FUNCTION Press to engage smoke	 SMOKING FUNCTION Press to engage smoke

USE APPROXIMATE COOKING TIMES SHOWN FOR FULL OR PARTIAL LOADS

PRESS START

START STOP

MAXIMUM CAPACITY

MODEL 6•10iN/SK	MODEL 10•10iN/SK	MODEL 7•14i/SK
5 full-size pans (GN 1/1)	9 full-size pans (GN 1/1)	12 full-size pans (GN 1/1) 6 full-size sheet pans

PAN SIZES

FINAL INTERNAL PRODUCT TEMPERATURE

PAN SIZES Full-size Pans: 20" x 12" x 2-1/2" Full-size Sheet Pans: 18" x 26" x 1" (GN 1/1: 530mm x 325mm x 20mm)	165°F (74°C)
--	-----------------

STOP THE COOKING FUNCTION AT ANY TIME BY PRESSING THE STOP KEY.

Time and temperature settings are suggested guidelines only. Due to variations in product quality, weight, and desired degree of doneness the controls may require some adjustment from the time and temperatures shown. All cooking should be based on internal product temperatures.

START STOP

COMBITHERM SMOKER OVEN PROCEDURE

PRODUCT Fresh Salmon Fillets:
➤ 2-1/2 - 4 lb (1 - 2 kg) each

MATERIALS
▼
Clear Plastic Wrap
Paper Toweling
Wire Mesh Grids
Tweezers
Ice: 3 to 4 lb (1 to 2 kg)

 **FAN SPEED** Half Speed

 **WOOD CHIP CONTAINER** Full

PRESS & SET
1.

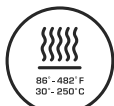
 **OVEN MODE**
Convection Mode

 **COOKING TEMPERATURE**
86°F (30°C)

 **TIMER**
APPROXIMATE COOK TIME
10 to 30 minutes per smoke
flavor preference

 **SMOKING FUNCTION**
Press to engage

▼ PRODUCT PREPARATION ▼

Remove bones from fillets with a tweezers to avoid rupturing tissue.

▼ SALTING ▼

50% Sea Salt or Kosher Salt

50% Granulated or Brown Sugar (FOR BEST COLOR)

To remove moisture from the raw salmon, blend salt and sugar mixture thoroughly and pack firmly around each fillet. Cover salt-filled pans with clear plastic wrap and refrigerate for 24 hours. Following the 24 hour refrigeration period, remove fillets from salt/sugar mixture and rinse thoroughly under cold, running water. Pat dry with paper toweling. Place fillets side-by-side on a sheet pan and return, uncovered, to the refrigerator for a period of 6 hours for the final drying period.

OVEN MUST BE AT ROOM TEMPERATURE BEFORE BEGINNING PROCEDURE.

Soak wood chips in water according to directions (5 minutes). Fill wood chip container full and insert in chip holder located at the back of the oven.

Fill pan with ice and locate pan in shelf directly above wood chip container.

Place prepared salmon fillets on a wire grid as indicated on the diagram and insert wire grid on oven shelf beginning with the top shelf position.

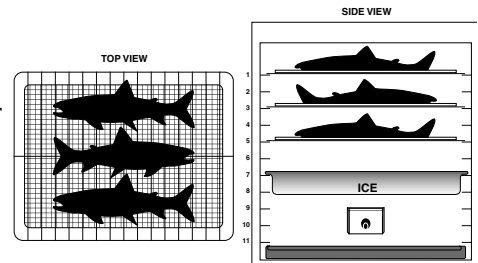

Insert probe into the center of the middle salmon fillet located in the top shelf position or central shelf position when smoking a full load (OPTIONAL). To maintain proper color, the internal temperature of the salmon must not exceed 77°F (25°C). For this reason, it is important to begin the smoking process with the oven at room temperature.

Close oven door and press the oven function keys to provide a smoking time period from 10 to 30 minutes depending on taste preference. When the timer cycles to the OFF position, the fillets must remain in the oven for a period of 30 minutes to 2 hours. Do not open the oven door during this period.

Following the required oven time, remove the fillets, cover with clear plastic wrap and refrigerate until fully chilled.

USE APPROXIMATE COOKING TIMES SHOWN FOR FULL OR PARTIAL LOADS

PRESS START

START STOP

MAXIMUM CAPACITY

MODEL 6•10iN/SK

5 half-size sheet pans

MODEL 10•10iN/SK

5 half-size sheet pans

MODEL 7•14i/SK

9 half-size sheet pans

PAN SIZES

PAN SIZES
➤

Half-size sheet pans: 18" x 13" x 1"
Full-size sheet pans: 18" x 26" x 1"

FINAL INTERNAL PRODUCT TEMPERATURE

NOT TO EXCEED 77°F (25°C)

STOP OVEN FUNCTION AT ANY TIME BY PRESSING THE STOP KEY.

Time and temperature settings are suggested guidelines only. Due to variations in product quality, weight, and desired degree of doneness the controls may require some adjustment from the time and temperatures shown. All cooking should be based on internal product temperatures.

START STOP

IMPORTANT SAFETY PRECAUTIONS



STEAM

For safe release of the cooking compartment steam, initially open the door approximately 2" (50mm) only. Stand behind the door as the hot steam is released.

DO NOT USE THE ATTACHED HAND-HELD HOSE TO SPRAY ANYTHING OTHER THAN THE INTERIOR OF THE COMBITHERM OVEN COMPARTMENT. AT NO TIME SHOULD THE EXTERIOR OF THE OVEN BE STEAM CLEANED, HOSED-DOWN WITH THE HAND-SPRAYER, FLOODED WITH WATER, OR FLOODED WITH LIQUID SOLUTION OF ANY KIND.

DO NOT USE THE SPRAY HOSE IN A HOT COOKING COMPARTMENT. ALLOW THE OVEN TO COOL TO A MINIMUM OF 150°F (66°C).

DO NOT USE HIGH PRESSURE WATER CLEANING METHODS ON THE INTERIOR OR EXTERIOR OF THE COMBITHERM OVEN.

DO NOT HANDLE PANS CONTAINING LIQUID OR SEMI LIQUID PRODUCTS POSITIONED ABOVE EYE LEVEL OF THE OPERATOR. SUCH PRODUCTS CAN SCALD AND CAUSE SERIOUS INJURY.

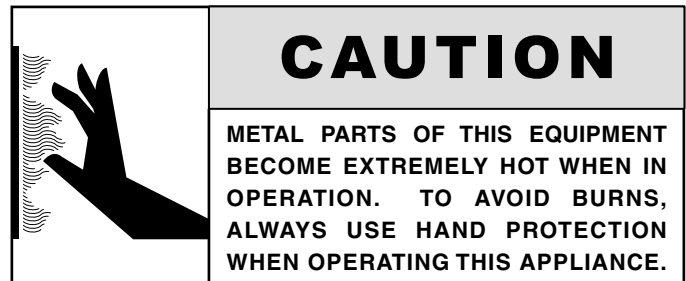

USE AUTHORIZED COMBITHERM LIQUID OVEN CLEANER ONLY.

UNAUTHORIZED CLEANING AGENTS MAY DISCOLOR OR HARM INTERIOR SURFACES OF THE OVEN. READ AND UNDERSTAND LABEL AND MATERIAL SAFETY DATA SHEET BEFORE USING THE OVEN CLEANER.

FOR OPERATOR SAFETY

NOTE AND OBSERVE ALL SAFETY PRECAUTIONS LOCATED THROUGHOUT THIS MANUAL.

CLEANING AND PREVENTIVE MAINTENANCE

PROTECTING STAINLESS STEEL SURFACES



It is important to guard against corrosion in the care of stainless steel surfaces. Harsh, corrosive, or inappropriate chemicals can completely destroy the protective surface layer of stainless steel. Abrasive pads, steel wool, or metal implements will abrade surfaces causing damage to this protective coating and will eventually result in areas of corrosion. Even water, particularly hard water that contains high to moderate concentrations of chloride, will cause oxidation and pitting that result in rust and corrosion. In addition, many acidic foods spilled and left to remain on metal surfaces are contributing factors that will corrode surfaces.

Proper cleaning agents, materials, and methods are vital to maintaining the appearance and life of this appliance. Spilled foods should be removed and the area wiped as soon as possible but at the very least, a minimum of once a day. Always thoroughly rinse surfaces after using a cleaning agent and wipe standing water as quickly as possible after rinsing.

CLEANING AGENTS

Use non-abrasive cleaning products designed for use on stainless steel surfaces. Cleaning agents must be chloride-free compounds and must not contain quaternary salts. Never use hydrochloric acid (muriatic acid) on stainless steel surfaces. Always use the proper cleaning agent at the manufacturer's recommended strength. Contact your local cleaning supplier for product recommendations.

CLEANING MATERIALS

The cleaning function can usually be accomplished with the proper cleaning agent and a soft, clean cloth. When more aggressive methods must be employed, use a non-abrasive scouring pad on difficult areas and make certain to scrub with the visible grain of surface metal to avoid surface scratches. Never use wire brushes, metal scouring pads, or scrapers to remove food residue.



	<p>! CAUTION</p> <p>TO PROTECT STAINLESS STEEL SURFACES, COMPLETELY AVOID THE USE OF ABRASIVE CLEANING COMPOUNDS, CHLORIDE BASED CLEANERS, OR CLEANERS CONTAINING QUATERNARY SALTS. NEVER USE HYDROCHLORIC ACID (MURIATIC ACID) ON STAINLESS STEEL. NEVER USE WIRE BRUSHES, METAL SCOURING PADS OR SCRAPERS.</p>
---	--

Preventive Maintenance

In addition to the routine cleaning and maintenance procedures, there are several additional steps to be taken for both sanitation purposes and to keep the oven running at top operating efficiency. These additional safeguards will help prevent inconvenient down time and costly repairs.

- **DO NOT DISPOSE OF GREASE, FAT, OR SOLID WASTE DOWN THE OVEN DRAIN.**

Fats and solids will eventually coagulate in the drain system, causing blockage. Consequently, water will back-up into the condenser and interior oven compartment, resulting in an oven that is inoperable.

- **MAKE CERTAIN THE DRAIN SCREEN IS ALWAYS IN PLACE. REMOVE ANY SOLID WASTE MATERIAL FROM THE DRAIN SCREEN BEFORE IT ENTERS THE DRAIN SYSTEM.** The routine removal of solids from the drain screen will help prevent blockage.

- **USE THE AUTHORIZED COMBITHERM OVEN CLEANER ONLY.** The use of unauthorized cleaning agents may discolor or harm the interior surfaces of the oven.

- **TO PROLONG THE LIFE OF THE DOOR GASKET, REMOVE AND CLEAN THIS ITEM DAILY.** The acids and related compounds found in fat, particularly chicken fat, will considerably weaken the composition of the gasket unless cleaned on a daily basis.

- **TO ADDITIONALLY PROTECT GASKET LIFE, ALLOW OVEN DOOR TO REMAIN SLIGHTLY OPEN AT THE END OF THE PRODUCTION DAY.** An open door will relieve the pressure on the door gasket.

- **ROUTINELY CLEAN DOOR HINGES.** Open oven door to relieve tension. Clean all parts of the hinge.



⚠ DANGER

AT NO TIME SHOULD THE INTERIOR OR EXTERIOR BE STEAM CLEANED, HOSED DOWN, OR FLOODED WITH WATER OR LIQUID SOLUTION OF ANY KIND. DO NOT USE WATER JET TO CLEAN.

SEVERE DAMAGE OR ELECTRICAL HAZARD COULD RESULT.

WARRANTY BECOMES VOID IF APPLIANCE IS FLOODED.

Routine Cleaning Requirements

DAILY OVEN CLEANING

To be performed at the end of each production day or between production shifts.

DAILY GASKET CLEANING

It is important to prolong the life of the oven gasket by cleaning this item on a daily basis. Routine cleaning will help protect the composition of the gasket from deterioration caused by acidic foods. After allowing the oven to cool, remove pull-out gasket and wash in hot, soapy water. *Do not* place in the dishwasher.

Always replace the gasket before cleaning the oven interior or operating the oven.



MONTHLY CLEANING

- **WATER INTAKE FILTER**
- **DRAIN PIPE**
- **FAN**
- **FILTER BETWEEN HOSE AND HANDLE**
- **SPRAY HEAD**

COMBITHERM® CLEANING & MAINTENANCE

NOTE

USE AUTHORIZED COMBITHERM LIQUID OVEN CLEANER ONLY.



DANGER

RUBBER GLOVES AND PROTECTIVE EYE WEAR MUST BE WORN WHEN USING THE OVEN CLEANER.



WARNING

WATER SUPPLY MUST BE OPEN WHEN CLEANING PROGRAM IS ACTIVATED.

VERIFY WATER SUPPLY BEFORE STARTING CLEANING PROGRAM.

Unauthorized cleaning agents may discolor or harm interior surfaces of the oven. Read and understand label and material safety data sheet before using the oven cleaner.

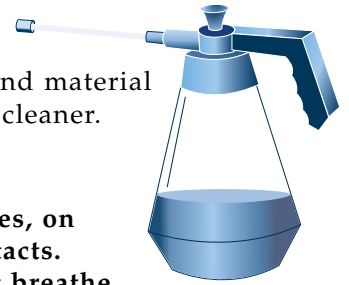

Causes severe burns. Do not get in eyes, on skin, or on clothing. Do not wear contacts. Harmful or fatal if swallowed. Do not breathe mist. Use in well ventilated area. Keep out of reach of children. Do not use on aluminum. Do not mix with anything but water.

THOROUGHLY RINSE EMPTY CONTAINER WITH WATER AND SAFELY DISCARD.

S CONTROL OPTION

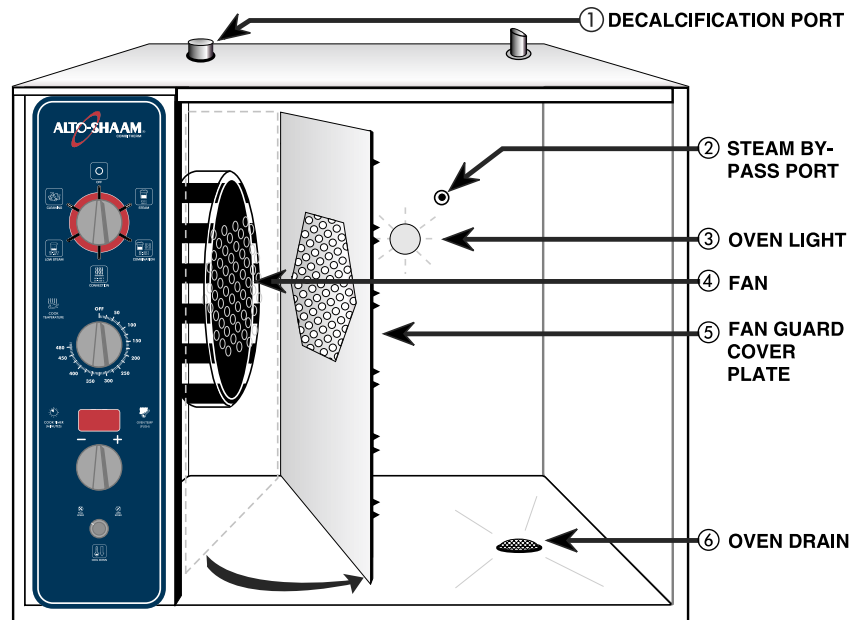

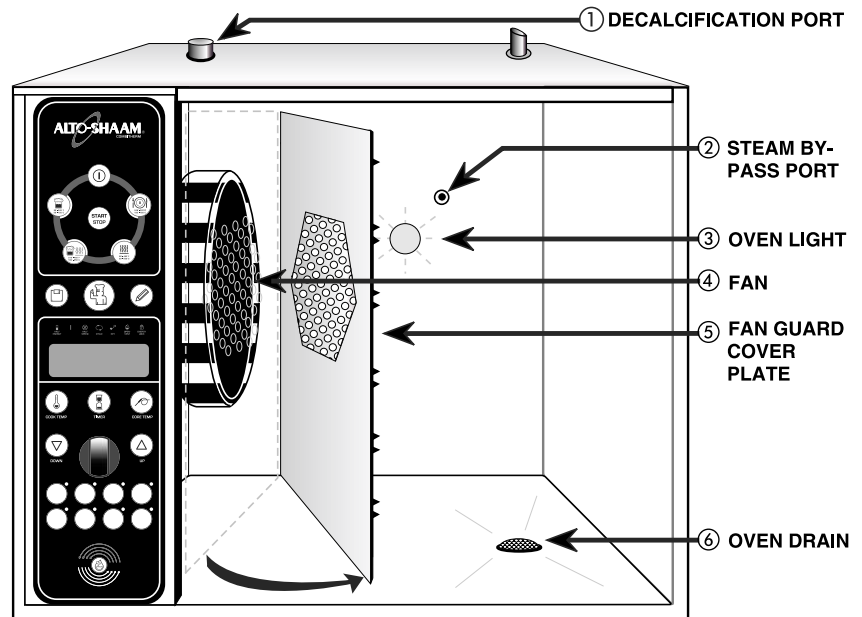

STANDARD CONTROL
DELUXE CONTROL



DAILY OVEN CLEANING



The Combitherm automatic cleaning function selects the proper temperature for each step of the cleaning process.

1.  Remove all food scraps and residue from the oven drain.
Close the oven door securely.
Rotate the power knob to the cleaning symbol. 

THE OVEN WILL BEGIN THE FIRST STEP IN A TWO-STEP CLEANING CYCLE
• **10 MINUTES** at a steam temperature of 86°F (30°C)

2.  When the buzzer signals the end of the first step, open the oven door to deactivate the audible signal. **Cln** will appear in the display.
3. Wearing safety glasses and rubber gloves, remove the drain screen and spray Combitherm liquid oven cleaner directly into the oven drain ⑥. Replace the drain screen.
4. Generously spray the interior oven surfaces with an even coat of Combitherm Liquid Oven Cleaner. Spray all built-in components, shelves, side racks, and pans.
5. Loosen the thumb screw(s) and swing Fan Guard Cover Plate ⑤ toward the back of the oven. Spray the back of the Fan Guard Cover Plate, the oven fan ④, and the left-hand side of the oven. Close the swing-out Cover Plate ⑤. Lock the cover into place and tighten thumb screw(s).
6. Insert the Combitherm Liquid Oven Cleaner spray nozzle directly into the Steam By-Pass Port ② and spray several times.
7. Securely close the oven door.

THE OVEN WILL BEGIN THE SECOND STEP IN THE TWO-STEP CLEANING CYCLE
• **10 MINUTES** at a steam temperature of 86°F (30°C)

8.  When the buzzer signals the end of the second step, open the oven door to deactivate the audible signal.
9. Use the hand held hose and direct a stream of water into the Steam By-Pass Port ② to rinse away oven cleaner residue.
10. Rinse the interior and all sprayed components with the hand-held hose. Make certain to thoroughly rinse all surfaces to remove any cleaning solution residue. Use a non-abrasive cleaning pad for any problem areas.
11. Loosen the thumb screw(s) and swing Fan Guard Cover Plate toward the back of the oven. Thoroughly rinse the back of the Fan Guard Cover Plate, the oven fan, and the left-hand side of the oven. Close the swing out Cover Plate. Lock the cover into place and tighten thumb screw(s).

DAILY OVEN CLEANING

STANDARD CONTROL
DELUXE CONTROL

**DO NOT SPRAY CLEANER
INTO A HOT OVEN.**

ALLOW THE OVEN TO COOL TO 150°F (60°C).

The temperature in the display indicates the air temperature inside the oven compartment and not the interior walls of the oven. Always make certain to allow the oven walls to cool to a minimum of 150°F (60°C) before spraying the compartment with oven cleaner.

1. Remove all food scraps and residue from the oven drain ⑥.
2. Wearing safety glasses and rubber gloves, remove the drain screen and spray Combitherm liquid oven cleaner directly into the oven drain ⑥. Replace the drain screen.
3. Generously spray the interior oven surfaces with an even coat of Combitherm Liquid Oven Cleaner. Spray all built-in components, shelves, side racks, and pans.
4. Once a week, loosen the thumb screw(s) and swing Fan Guard Cover Plate ⑤ toward the back of the oven. Spray the back of the Fan Guard Cover Plate, the oven fan ④, and the left-hand side of the oven. Close the swing out Cover Plate ⑤. Lock the cover into place and tighten thumb screw(s).
5. Insert the Combitherm Liquid Oven Cleaner spray nozzle directly into the Steam By-Pass Port ② and spray several times.
6. Securely close the oven door.

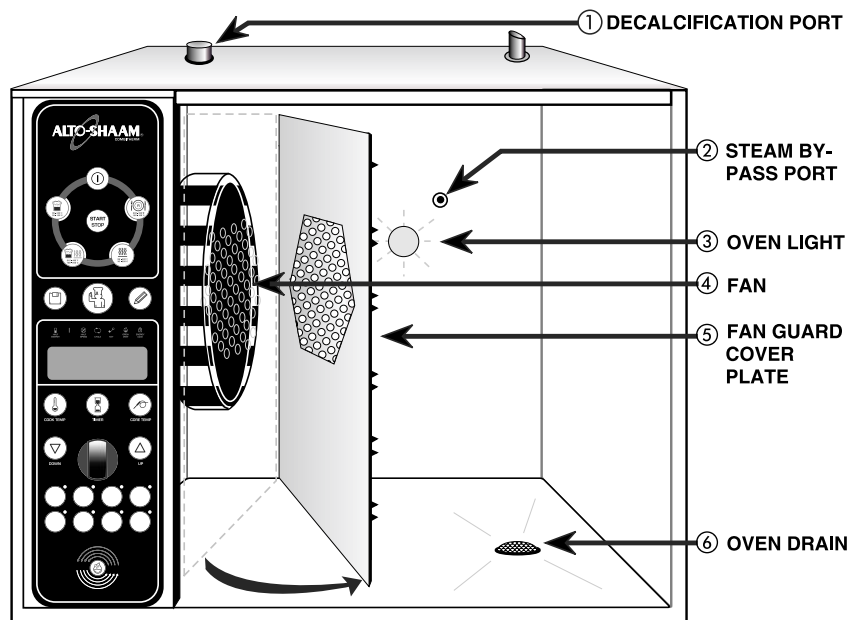

COMBITHERM® CLEANING & MAINTENANCE

AUTOMATIC CLEANING PROGRAM

**STANDARD CONTROL
DELUXE CONTROL**

The Combitherm automatic cleaning function selects the proper temperature for each step of the cleaning process.

With the oven power  on:

 PRESS THE CHEF FUNCTION KEY.

➔ Rotate the adjustment knob until the clean symbol  is highlighted in the display.

 PRESS THE CHEF FUNCTION KEY.

➔ Press the up Δ and down ∇ arrow keys or rotate the adjustment knob to select YES for the automatic cleaning function.

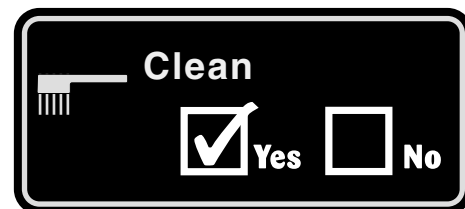

 PRESS THE CHEF FUNCTION KEY TO CONFIRM THE SETTING AND START THE CLEANING PROGRAM.

THE OVEN WILL BEGIN A 20 MINUTE, 2-STEP CLEANING CYCLE.

- 10 minutes at 86°F (30°C) to allow the cleaning agent to work
- 10 minutes at full steam temperature of 212°F (100°C) to clean the oven



FOR DELUXE OVENS WITH A PROGRAMMED MENU KEY

FOLLOW STEPS 1 THROUGH 6 ON THE PRECEDING PAGE.





With the oven power  on:

 ➔ PRESS THE PROGRAMMED MENU KEY.

Rotate the adjustment knob to program 250 = CLEAN.

 PRESS THE START KEY.

DELUXE MODELS CAN ALSO BE CLEANED AS SHOWN IN THE PREVIOUS INSTRUCTIONS.

7. When the buzzer signals the end of the cleaning process, press the start/stop key  to deactivate the audible signal or open the oven door.
8. With the door open, use the hand held hose and direct a stream of water into the Steam By-Pass Port  to rinse away oven cleaner residue.
9. Rinse the interior and all sprayed components with the hand-held hose. Make certain to thoroughly rinse all surfaces to remove any cleaning solution residue. Use a non-abrasive cleaning pad for any problem areas.
10. Loosen the thumb screw(s) and swing Fan Guard Cover Plate  toward the back of the oven. Thoroughly rinse the back of the Fan Guard Cover Plate, the oven fan, and the left-hand side of the oven. Close the swing out Cover Plate . Lock the cover into place and tighten thumb screw(s).

LEAVE DOOR SLIGHTLY OPEN AFTER CLEANING

CONTROL RESET

There is a remote possibility in the day-to-day operation of the Combitherm that the control could lock or freeze. If this occurs, the control is easy to reset.



PRESS AND HOLD the Power Key for a period of 5 seconds.

Release the Power Key.

The control will reset itself within approximately 15 seconds.

WHEN RESET, THE DISPLAY WILL INDICATE THE TIME AND DATE AND THE CONTROLS WILL BE FULLY FUNCTIONAL.

EMERGENCY OPERATION

In the event of an error code, operation of the Combitherm can be continued on a limited basis for a short duration. Cooking times may be longer than normal operation and close monitoring of the cooking process is recommended. Contact an authorized service agency immediately if the problem cannot be rectified with simple steps in the troubleshooting guidelines located in this manual. Error conditions under which continued operation can be conducted are indicated by YES in the chart shown below.

When the oven malfunctions, an error code will appear in the display.



PRESS THE START/STOP KEY TO ACKNOWLEDGE THE ERROR.

The keys for the usable operational modes will begin to flash and can be operated normally.



SELECT AND PRESS ONE OF THE COOKING MODES INDICATED.

The oven control will only respond to the oven mode keys flashing.

SET THE OVEN CONTROLS AS IF OPERATING UNDER NORMAL CIRCUMSTANCES.

Depending on the error code involved, oven function, such as temperature range, may be limited.



PRESS THE START/STOP KEY TO BEGIN THE COOKING PROCESS.



PRESS THE START/STOP KEY WHEN THE TIMER EXPIRES.

WHEN THE OVEN FAULT IS CORRECTED, THE COMBITHERM WILL RETURN TO NORMAL OPERATION.

EMERGENCY OPERATION

ERROR CODE	DISPLAY MESSAGE	ELECTRIC	STEAM ¹ MODE	SUPERHEATED STEAM MODE	CONVECTION MODE	RETERM MODE	DELTA-T MODE
E02	EL-temperature too high CONTROL COMPARTMENT TEMP	YES	YES	Up to 284°F (140°C)	Up to 284°F (140°C)	Up to 284°F (140°C)	Up to 284°F (140°C)
E03	Fan Fault BLOWER FAN	YES	Up to 212°F (100°C)	NO	NO	NO	NO
E04	EL-fan fault CONTROL COOLING FAN	YES	YES	Up to 284°F (140°C)	Up to 284°F (140°C)	Up to 284°F (140°C)	Up to 284°F (140°C)
E15	Condenser oven temperature HIGH CONDENSATE TANK TEMP	YES	NO	NO	Up to 356°F (180°C)	NO	YES
E21	Oven probe error TEMPERATURE PROBE	YES	212°F only (100°C)	NO	NO	NO	NO
E22	CTC error TEMPERATURE PROBE	YES	YES	YES	YES	YES	YES
E23	SG-probe error STEAM GENERATOR PROBE B4	YES	YES	YES	YES	YES	YES
E24	Bypass probe error	YES	Up to 210°F (99°C)	NO	YES	NO	YES
E25	Condenser probe error B3 PROBE	YES	YES ²	Up to 356°F ² (180°C)	Up to 356°F ² (180°C)	Up to 356°F ² (180°C)	YES ²
E81	Program memory error	YES	YES	YES	YES	YES	YES
E83	Algorithm error	YES	YES	YES	YES	YES	YES
E89	12C error	YES	YES	YES	YES	YES	YES

¹ Cooking time increases significantly. Food on the upper shelves is finished first.

² Water injection into the condenser is activated for the entire cooking mode (high water consumption).



Alto-Shaam has established a twenty-four hour emergency service call center to offer immediate customer access to a local authorized service agency outside of standard business hours. The emergency service access is provided exclusively for Alto-Shaam equipment and is available throughout the United States through the use of Alto-Shaam's toll-free number. Emergency service access is available seven days a week including holidays.

TROUBLESHOOTING

CAUTION

In the event of a Combitherm malfunction during operation, an error code and message will appear in the display to assist in finding a rapid solution to the problem. The following is a list of all error codes including the possible cause along with a solution.

THIS SECTION IS PROVIDED FOR THE ASSISTANCE OF QUALIFIED SERVICE TECHNICIANS ONLY AND IS NOT INTENDED FOR USE BY UNTRAINED OR UNAUTHORIZED SERVICE PERSONNEL.

ERROR CODE	DESCRIPTION OF ERROR	POSSIBLE CAUSE/REMEDY
E02	Excessive temperature in service area: An additional fan will engage at a temperature of 113°F (45°C) and the error message will occur at a service area temperature of 176°F (80°C).	Auxiliary 12 V fan does not turn on due to defective thermostat or contactor. Ventilation vents are blocked due to inefficient distance from wall at installation site. Minimum distance to equipment such as fryers, grills, kettles, etc. has not been maintained.
E03	Fan motor shuts down from a tripped internal PTC.	A phase from the main power supply is missing. The fan motor is defective. Power phase reversed causing fan to run in reverse. A fuse is tripped.
E03	Motor shuts down fan.	Trip circuit has been set too low. Direction of motor rotation is wrong. A phase is missing from the main power supply. The motor protection switch is defective. Power phase reversed causing fan to run in reverse. The fan motor is defective.
E04	Auxiliary 120 fan motor not running.	Auxiliary fan is defective. Defective wiring or loose connection to auxiliary fan.
E11	Oven probe (N6 thermocouple) measures a temperature in excess of 572°F (300°C).	Convection contactors are burned and no longer disengage. Motor not operating due to two defective F10 fuses.
E15	Condenser probe (B3 thermocouple) measures a temperature in excess of 212°F (100°C).	Water tap is closed. Oven is connected to warm water supply. Inlet filter on solenoid valve is dirty. Condenser cooling solenoid valve or solenoid valve coil is defective.
E25	Condenser probe (B3 thermocouple) is interrupted.	Probe connection is bad at X6 on the control module. Condenser probe (B3) is interrupted or defective. Bad probe connection.
E26	Safety temperature probe (N8 thermocouple) is interrupted.	Probe connection is bad at X6 on the control module. STB steam generator probe (N8) is interrupted or defective. Bad probe connection.
E80	ID (identity) error.	The electronic control cannot differentiate between gas or electric operation and disconnects all circuit connections. Contact problem on X3 connection.
E81	Cooking procedure - programming error.	Unit has been changed from Fahrenheit to Celsius.
E82	Preset program or cleaning program has become corrupt.	The sequence must be deleted and reprogrammed.
E83	Communication problem between display and relay board.	Pres and hold the Chef function key while in the OFF mode and verify both the BM and SM software versions.
E96	Incompatibility between software and hardware.	Communication cable is loose between relay board and display board. Communications cable defective.

Parts List • Combitherm ML Boiler-Free Electric

PART DESCRIPTION	6•05	6•10iN	10•10iN	7•14i
DOOR PARTS:				
DOOR, ARM (MARINE MODELS ONLY)	CT-22887	CT-22887	CT-22887	CT-22887
DOOR, ARM PLATE (MARINE MODELS ONLY)	CT-22885	CT-22885	CT-22885	CT-22885
DOOR BUSHING, ARM (MARINE MODELS)	CT-22886	CT-22886	CT-22886	CT-22886
DOOR, CLIP	LT-25080	LT-25080	LT-25080	LT-25080
DOOR DRAIN, OUTER	DA-25073	DA-25073	DA-25073	DA-25073
DOOR, GLASS, INNER	GL-25384	GL-25384	GL-25902	GL-25386
DOOR, GLASS, OUTER	GL-25165	GL-25165	GL-25901	GL-25158
DOOR, HANDLE INSERT	HD-23084	HD-23084	HD-23084	HD-23084
DOOR HANDLE, RIGHT HAND	HD-2934	HD-2934	HD-2934	HD-2934
DOOR LATCH, INNER GUARD PLATE	LT-25394	LT-25394	LT-25394	LT-25394
DOOR LATCH, RIGHT HAND	LT-25058	LT-25058	LT-25058	LT-25058
DOOR LATCH INSET, RIGHT HAND	LT-25836	LT-25836	LT-25836	LT-25836
DOOR, LATCH MAGNET SWITCH	LT-3738	LT-3738	LT-3738	LT-3738
DOOR LATCH MOUNTING HARDWARE	SC-22768	SC-22768	SC-22768	SC-22768
DOOR, INNER BUMPER	BM-25072	BM-25072	BM-25072	BM-25072
DOOR, INNER BUMPER STOP	BM-25089	BM-25089	BM-25089	BM-25089
DOOR, FULL ASSEMBLY	5000612	5000612	5002486	5000282
DOOR, MAGNET	MA-25081	MA-25081	MA-25081	MA-25081
DRIP TRAY	5000582	5000582	5000582	5000294
GASKET, DOOR	GS-25550	GS-25550	GS-26213	GS-23903
GASKET, DOOR, ADHESIVE	GS-23622	GS-23622	GS-23622	GS-23622
HINGE, ANCHOR	HG-25078	HG-25078	HG-25078	HG-25078
HINGE, INNER DOOR HINGE	HG-25111	HG-25111	HG-25111	HG-25111
HINGE, INNER DOOR TOP CORNER	HG-25390	HG-25390	HG-25390	HG-25390
HINGE, INNER DOOR BUTTON CORNER	HG-25391	HG-25391	HG-25391	HG-25391
HINGE, LOWER PLATE	HG-25100	HG-25100	HG-25100	HG-25100
HINGE, LOWER DOOR RATCHET	HG-25101	HG-25101	HG-25101	HG-25101
HINGE, UPPER PLATE	HG-25099	HG-25099	HG-25099	HG-25099
HINGE, UPPER DOOR RATCHET	HG-25079	HG-25079	HG-25079	HG-25079
HINGE, UPPER PLATE MTG HARDWARE:				
— SCREW, AXIS	SC-25102	SC-25102	SC-25102	SC-25102
— WASHER, COVERING	WS-25127	WS-25127	WS-25127	WS-25127
— WASHER, ECCENTRIC BLOCK	WS-25124	WS-25124	WS-25124	WS-25124
— WASHER, SCHMORR STYLE	WS-25478	WS-25478	WS-25478	WS-25478
— HINGE, TOP STOP	HG-25077	HG-25077	HG-25077	HG-25077

Parts List • Combitherm ML Boiler-Free Electric

PART DESCRIPTION	6•05	6•10iN	10•10iN	7•14i
DOOR PARTS (CONTD.):				
MOUNT, RELAY BOARD	5000277	5000277	5000277	5000277
PANEL, CONTROL	5000287	5000287	5000287	5000287
ELECTRICAL/ELECTRONIC PARTS:				
BOARD, DISPLAY CONTROL	BA-33732	BA-33732	BA-33732	BA-33732
— ADJUSTING ROCKER (COMPLETE)	KN-33734	KN-33734	KN-33734	KN-33734
— ADJUSTING ROCKER KNOB	KN-33735	KN-33735	KN-33735	KN-33735
— BUSHING, DISTANCE	BU-25094	BU-25094	BU-25094	BU-25094
— NUT, KNURLED M3	NU-25095	NU-25095	NU-25095	NU-25095
BOARD, LED CLOSED SYSTEM	BA-33733	BA-33733	BA-33733	BA-33733
BOARD, POWER SUPPLY	BA-33554	BA-33554	BA-33554	BA-33554
BOARD, PROGRAM MODULE (DELUXE MODELS)	BA-33742	BA-33742	BA-33742	BA-33742
— CONNECTOR, X11/X12	CR-33743	CR-33743	CR-33743	CR-33743
BOARD, RELAY CONTROL	BA-33736	BA-33736	BA-33736	BA-33736
BUSHING, MOTOR SHAFT	BU-22213	BU-22213	BU-22213	BU-22213
CABLE, COMMUNICATION				
— SM TO BM	CB-33750	CB-33750	CB-33750	CB-33750
CONNECTOR, 9 POLES	TM-33774	TM-33774	TM-33774	TM-33774
CONNECTOR, 16 POLES	TM-33773	TM-33773	TM-33773	TM-33773
CONTACTORS, TYPE # DL4K-01, K-51/52/53	CN-3652	CN-3652	CN-3652	CN-3652
CONTACTORS, TYPE # DL7K-4H, K-1	CN-3654	CN-3654	CN-3654	CN-3654
CONTACTORS, TYPE # DL15K-00, K-41/42	CN-3731	CN-3731	CN-3731	CN-3731
ELEMENT, HEATING, CONVECTION	EL-33573	EL-3854	EL-3761	EL-3761
ELEMENT, HEATING, CONVECTION MNTG HARDWARE				
— WASHERS, FLAT	WS-22294	WS-22294	WS-22294	WS-22294
— WASHERS, SPLIT LOCK	WS-22300	WS-22300	WS-22300	WS-22300
— HEX NUTS	NU-22286	NU-22286	NU-22286	NU-22286
— NUTS	—	NU-33062	NU-33062	NU-33062
EMI FILTERS, CONTACTOR (380-415V MODEL ONLY)	—	FI-33990	FI-33990	—
EMI FILTERS, SOLENOID (380-415V MODEL ONLY)	—	FI-33989	FI-33989	—
FAN, INTAKE, AUXILIARY DC4112NX	FA-3568	FA-3568	FA-3568	FA-3568
FAN, WHEEL	WH-33838	WH-33758	WH-33758	WH-33758

Parts List • Combitherm ML Boiler-Free Electric

PART DESCRIPTION	6•05	6•10iN	10•10iN	7•14i
ELECTRICAL/ELECTRONIC PARTS (CONTD.):				
FUSE, SLOW-BLO 2AMP, 250V	FU-33184	FU-33184	FU-33184	FU-33184
FUSE, NEOZED 6.3AMP	FU-33452	FU-33452	FU-33452	FU-33452
FUSE HOLDER, DIN RAIL MOUNT				
— WITH DISCONNECT	FU-33756	FU-33756	FU-33756	FU-33756
— 380-415V ONLY	—	FU-33451	FU-33451	—
FUSE HOLDER, 15AMP CLASS G (1PH ONLY)	FU-3772	FU-3772	FU-3772	FU-3772
FUSE HOLDER, 60 AMP, 3POL, CLS G (440-480v 3PH ONLY)	—	—	FU-33039	FU33039
FUSE, 15AMP CLASS G	FU-3775	FU-3775	FU-3775	FU-3775
FUSE HOLDER, 15AMP, 3POL, CLS G (208-240v 3PH ONLY)	FU-3842	FU-3842	FU-3842	FU-3842
FUSE HOLDER AND COVER, NEOZED (380-415v MODEL ONLY)	—	FU-33444	FU-33444	—
— ADAPTER RING, FUSE	—	FU-33448	FU-33448	—
— SUPPORT, FUSE	—	FU-33445	FU-33445	—
MOTOR CAPACITOR, 12MFD (208-240v, 1PH ONLY)	FA-33499	FA-33499	FA-33499	FA-33499
MOTOR CAPACITOR, 25MFD (208-240v, 1PH ONLY)	FA-33465	FA-33465	FA-33465	FA-33465
MOTOR, SUB ASSEMBLY (208-240v 3PH SIMPLE AND STANDARD CONTROLS)	5000465	—	—	—
MOTOR, SUB ASSEMBLY (208-240v, 1PH/3PH)	5000276	5000276	5000276	5000276
MOTOR, SUB ASSEMBLY (380-415V, 440-480V)	—	5000602	5000602	5000602
NUT, KNURLED M3	NU-25095	NU-25095	NU-25095	NU-25095
PANEL, CONTROL OVERLAY PROGRAM OPTIONS (DELUXE MODELS)	—	PE-25345	PE-25345	PE-25345
PANEL, CONTROL OVERLAY (STANDARD MODELS)	PE-25319	PE-25319	PE-25319	PE-25319
PANEL, CONTROL OVERLAY (DELUXE MODELS)	PE-25048	PE-25048	PE-25048	PE-25048
PANEL LOCK-DOWN SCREW	CL-24089	CL-24089	CL-24089	CL-24089
PROBE, MULTI-POINT CTC	PR-33746	PR-33746	PR-33746	PR-33746
PROBE, OVEN TEMPERATURE (1650mm WIRE LENGTH)	PR-33724	PR-33724	PR-33724	PR-33724
PROBE, STEAM BYPASS	—	—	—	PR-33751
PROBE SEAL, THERMOCOUPLE	SA-25061	SA-25061	SA-25061	SA-25061
RELAY, PANEL MOUNT	RL-33483	—	—	—
SWITCH, MOTOR PROTECTION				
(1PH ONLY)	SW-33500	SW-33500	SW-33500	SW-33500
(3PH ONLY)	SW-33378	SW-33378	SW-33378	SW-33378
TERMINAL, GROUND, 4mm	TM-3781	TM-3781	TM-3781	TM-3781
TERMINAL, GROUND, 10mm	TM-3932	TM-3932	TM-3932	TM-3932
TERMINAL PARTITION, 4mm	TM-3783	TM-3783	TM-3783	TM-3783

Parts List • Combitherm ML Boiler-Free Electric

PART DESCRIPTION	6•05	6•10iN	10•10iN	7•14i
ELECTRICAL/ELECTRONIC PARTS (CONTD.):				
TERMINAL PARTITION, 16mm	TM-3785	TM-3785	TM-3785	TM-3785
TERMINAL, PLUG	TM-3926	TM-3926	TM-3926	TM-3926
TERMINAL BLOCK X1	TM-33747	TM-33747	TM-33747	TM-33747
TERMINAL BLOCK X2	TM-33748	TM-33748	TM-33748	TM-33748
TERMINAL BLOCK X3	TM-33749	TM-33749	TM-33749	TM-33749
TERMINAL BLOCK X10-X11, 4mm	TM-3778	TM-3778	TM-3778	TM-3778
TERMINAL BLOCK X10, 16mm	TM-3779	TM-3779	TM-3779	TM-3779
— TERMINAL JUMPER BAR (2 POLE)	TM-33675	TM-33675	TM-33675	TM-33675
— TERMINAL JUMPER BAR (3 POLE)	TM-33106	TM-33106	TM-33106	TM-33106
— TERMINAL JUMPER BAR (4 POLE)	TM-3787	TM-3787	TM-3787	TM-3787
THERMOSTAT, HIGH LIMIT	TT-3750	TT-3750	TT-3750	TT-3750
THERMOSTAT, HIGH LIMIT (1PH ONLY)	—	—	TT-3980	—
VALVE, SOLENOID	VA-25481	VA-25481	VA-25481	VA-25481
MECHANICAL PARTS:				
BOX, PRESSURE	5000585	5000585	5000585	5000585
BUSHING, MOTOR ASSEMBLY	BU-23894	BU-23894	BU-23894	BU-23894
BUSHING, SOCKET MEMBRANE, VENT	BU-22204	BU-22204	BU-22204	BU-22204
HOLDER, CTC PROBE	13412	13412	13412	13412
HOSE, CLEAR FLEX	HO-22255	HO-22255	HO-22255	HO-22255
HOUSING, SEAL, O-RING	SA-25139	SA-25139	SA-25139	SA-25139
LEGS, 2" (51mm) ADJUSTABLE	LG-23907	LG-23907	LG-23907	LG-23907
LAMP, COVER	CV-23896	CV-23896	CV-23896	CV-23896
LIGHT BULB	LP-3686	LP-3686	LP-3686	LP-3686
LIGHT, GLASS COVER	LP-33413	LP-33413	LP-33413	LP-33413
LIGHT SEAL	SA-23934	SA-23934	SA-23934	SA-23934
LIGHT, SOCKET RECEPTACLE	RP-3986	RP-3986	RP-3986	RP-3986

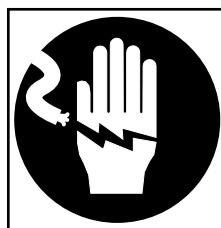

DANGER

**DISCONNECT UNIT FROM
POWER SOURCE BEFORE
CLEANING OR SERVICING.**

Parts List • Combitherm ML Boiler-Free Electric

PART DESCRIPTION	6•05	6•10iN	10•10iN	7•14i
MECHANICAL PARTS (CONTD.):				
PROBE PLUG ADAPTOR	PG-3826	PG-3826	PG-3826	PG-3826
PROBE PLUG SEAL	SA-22199	SA-22199	SA-22199	SA-22199
PROBE SEAL, INSERT	SA-22322	SA-22322	SA-22322	SA-22322
PROBE SEAL, CONE	SA-22321	SA-22321	SA-22321	SA-22321
PROBE SEAL, TOP	SA-22320	SA-22320	SA-22320	SA-22320
SCREW COVER, M6 NATURAL	SC-23936	SC-23936	SC-23936	SC-23936
SETUP, BOILERLESS				
— BOX, DISINTEGRATION	1001204	1001204	1001204	1001204
— TUBE, INJECTION	5000709	5000618	5000618	5000618
SHELVES	—	SH-2903	SH-2903	SH-22584
SIDERACKS	—	SR-22525	SR-22267	SR-23942
WASHER, CONICAL	—	13607	13607	13607
PLUMBING PARTS:				
CONDENSER TANK ASSEMBLY	5000693	5000608	5000608	5000286
CONDENSATE TANK COVER NUT	SC-24070	SC-24070	SC-24070	SC-24070
CONDENSATE TANK COVER SCREW	SC-23936	SC-23936	SC-23936	SC-23936
CONDENSER, INJECTION NOZZLE	5000284	5000284	5000284	5000284
CONDENSER, O-RING	SA-22212	SA-22212	SA-22212	SA-22212
CONDENSER, O-RING 8X2.5 EPDM	SA-23109	SA-23109	SA-23109	SA-23109
DRAIN, CAP	CP-23895	CP-23895	CP-23895	CP-23895
DRAIN SCREEN	DA-2943	DA-2943	DA-2943	DA-2943
FILL LINE ASSEMBLY	5000606	5000606	5000606	5000316
PIPE, DRAIN EXTENSION	PP-25137	PP-25137	—	—
HAND SHOWER				
— FULL ASSEMBLY	5000731	14442	14442	14442
— BRACKET	PB-23921	PB-23921	PB-23921	PB-23921
— HOSE, BALL VALVE	VA-22684	VA-22684	VA-22684	VA-22684
— VALVE, SPRAY	PB-25660	PB-23919	PB-23919	PB-23919
— HANDLE	PB-23920	PB-23920	PB-23920	PB-23920
— HOSE ASSEMBLY	PB-25661	PB-23922	PB-23922	PB-23922
HOSE, CONNECTOR ELBOW WITH SEAL	HO-22116	HO-22116	HO-22116	HO-22116
HOSE, MEASURING PIPE	5000708	5000708	5000620	5000301
HOSE, PUMP	HO-25070	HO-25070	HO-25070	HO-25070

Parts List • Combitherm ML Boiler-Free Electric

PART DESCRIPTION	6•05	6•10iN	10•10iN	7•14i
PLUMBING PARTS (CONTD.):				
HOSE, RADIATOR	HO-22254	HO-22254	HO-22254	HO-22254
HOSE, STEAM BYPASS	HO-2957	HO-2957	HO-2957	HO-2957
PROBE, MEASURE WELD	5000283	5000283	5000283	5000283
SCREEN FILTER	FI-2946	FI-2946	FI-2946	FI-2946
SEALS, O-RING	SA-22209	SA-22209	SA-22209	SA-22209
SEALS, O-RING, GAS VALVE	SA-23691	SA-23691	SA-23691	SA-23691
VALVE, FLOW CONTROL	VA-25549	VA-25549	VA-25549	VA-25549
WATER SUPPLY	5000617	5000617	5000617	5000617
S-CONTROL PARTS				
OVEN TEMPERATURE PROBE	PR-33724	PR-33724	PR-33724	PR-33724
S-CONTROL RELAY BOARD	BA-34031	BA-34031	BA-34031	BA-34031
POWER SUPPLY BOARD	BA-33554	BA-33554	BA-33554	BA-33554
CABLE, COMMUNICATION	CB-34033	CB-34033	CB-34033	CB-34033
PROGRAM BOARD	BA-34030	BA-34030	BA-34030	BA-34030
TEMPERATURE BOARD	BA-34029	BA-34029	BA-34029	BA-34029
TIMER/SPEED BOARD	BA-34028	BA-34028	BA-34028	BA-34028
PROGRAM/TEMPERATURE KNOB	KN-34037	KN-34037	KN-34037	KN-34037
TIMER KNOB	KN-34036	KN-34036	KN-34036	KN-34036
SPEED KNOB	KN-34035	KN-34035	KN-34035	KN-34035
PANEL, CONTROL	5002761	5002761	5002761	5002761
PLUG	PG-3827	PG-3827	PG-3827	PG-3827
FUSE, BUSSMAN	—	—	FU33581	—
FUSE, 45AMP, CLASS G	—	—	FU-33040	—



Parts List • Combitherm ML Boiler-Free Smoker Electric

PART DESCRIPTION	6•10iN/SK	10•10iN/SK	7•14i/SK
DOOR PARTS:			
DOOR, ARM (MARINE MODELS ONLY)	CT-22887	CT-22887	CT-22887
DOOR, ARM PLATE (MARINE MODELS ONLY)	CT-22885	CT-22885	CT-22885
DOOR BUSHING, ARM (MARINE MODELS)	CT-22886	CT-22886	CT-22886
DOOR, CLIP	LT-25080	LT-25080	LT-25080
DOOR DRAIN, OUTER	DA-25073	DA-25073	DA-25073
DOOR, GLASS, INNER (FOR DR-25143)	GL-25383	GL-25902	GL-25386
DOOR, GLASS, INNER (FOR DR-251640)	GL-25384	GL-25902	GL-25386
DOOR, GLASS, OUTER (FOR DR-25143)	GL-25154	GL-25901	GL-25158
DOOR, GLASS, OUTER (FOR DR-251640)	GL-25165	GL-25901	GL-25158
DOOR, HANDLE INSERT	HD-23084	HD-23084	HD-23084
DOOR HANDLE, RIGHT HAND	HD-2934	HD-2934	HD-2934
DOOR LATCH, INNER GUARD PLATE	LT-25394	LT-25394	LT-25394
DOOR LATCH, RIGHT HAND	LT-25058	LT-25058	LT-25058
DOOR LATCH INSET, RIGHT HAND	LT-25836	LT-25836	LT-25836
DOOR, LATCH MAGNET SWITCH	LT-3738	LT-3738	LT-3738
DOOR LATCH MOUNTING HARDWARE	SC-22768	SC-22768	SC-22768
DOOR, INNER BUMPER	BM-25072	BM-25072	BM-25072
DOOR, INNER BUMPER STOP	BM-25089	BM-25089	BM-25089
DOOR, FULL ASSEMBLY	5000439	5002486	5000282
DOOR, FULL ASSEMBLY (208V MODEL ONLY)	5000612	—	—
DOOR, MAGNET	MA-25081	MA-25081	MA-25081
DRIP TRAY	5000582	5000582	5000294
GASKET, DOOR	GS-25550	GS-26213	GS-23903
GASKET, DOOR, ADHESIVE	GS-23622	GS-23622	GS-23622
HINGE, ANCHOR	HG-25078	HG-25078	HG-25078
HINGE, INNER DOOR HINGE	HG-25111	HG-25111	HG-25111
HINGE, INNER DOOR TOP CORNER	HG-25390	HG-25390	HG-25390
HINGE, INNER DOOR BUTTON CORNER	HG-25391	HG-25391	HG-25391
HINGE, LIFT OFF WITH PIN	HG-2041	HG-2041	HG-2041
HINGE, LIFT OFF WITHOUT PIN	HG-2429	HG-2429	HG-2429
HINGE, LOWER PLATE	HG-25100	HG-25100	HG-25100
HINGE, LOWER DOOR RATCHET	HG-25101	HG-25101	HG-25101

Parts List • Combitherm ML Boiler-Free Smoker Electric

PART DESCRIPTION	6•10iN/SK	10•10iN/SK	7•14i/SK
DOOR PARTS (CONTD.):			
HINGE, UPPER PLATE	HG-25099	HG-25099	HG-25099
HINGE, UPPER DOOR RATCHET	HG-25079	HG-25079	HG-25079
HINGE, UPPER PLATE MTG HARDWARE:			
— SCREW, AXIS	SC-25102	SC-25102	SC-25102
— WASHER, COVERING	WS-25127	WS-25127	WS-25127
— WASHER, ECCENTRIC BLOCK	WS-25124	WS-25124	WS-25124
— WASHER, SCHMORR STYLE	WS-25478	WS-25478	WS-25478
— HINGE, TOP STOP	HG-25077	HG-25077	HG-25077
MOUNT, RELAY BOARD	5000277	5000277	5000277
PANEL, CONTROL	5000287	5000287	5000287
ELECTRICAL/ELECTRONIC PARTS:			
BOARD, DISPLAY CONTROL	BA-33732	BA-33732	BA-33732
— ADJUSTING ROCKER (COMPLETE)	KN-33734	KN-33734	KN-33734
— ADJUSTING ROCKER KNOB	KN-33735	KN-33735	KN-33735
— BUSHING, DISTANCE	BU-25094	BU-25094	BU-25094
— NUT, KNURLED M3	NU-25095	NU-25095	NU-25095
BOARD, LED CLOSED SYSTEM	BA-33733	BA-33733	BA-33733
BOARD, POWER SUPPLY (208V MODELS)	BA-33554	BA-33737	BA-33737
BOARD, POWER SUPPLY	BA-33554	BA-33554	BA-33554
BOARD, PROGRAM MODULE (DELUXE MODELS)	BA-33742	BA-33742	BA-33742
— CONNECTOR, X11/X12	CR-33743	CR-33743	CR-33743
BOARD, RELAY CONTROL	BA-33736	BA-33736	BA-33736
BUSHING, MOTOR SHAFT	BU-22213	BU-22213	BU-22213
CABLE, COMMUNICATION			
— SM TO BM	CB-33750	CB-33750	CB-33750
— SMOKE HEATER, 208-240V	CB-3538	CB-3538	CB-3538
CONNECTOR, 9 POLES	TM-33774	TM-33774	TM-33774
CONNECTOR, 16 POLES	TM-33773	TM-33773	TM-33773
CONNECTOR, X11/X12 (COSTCO MODEL ONLY)	—	—	CR-33739
CONTACTORS, TYPE # DL4K-01, K-51/52/53	CN-3652	CN-3652	CN-3652
CONTACTORS, TYPE # DL7K-4H, K-1	CN-3654	CN-3654	CN-3654
CONTACTORS, TYPE # DL15K-00, K-41/42	CN-3731	CN-3731	CN-3731
CONVERSION WIRES	5003375	5003375	5003375

Parts List • Combitherm ML Boiler-Free Smoker Electric

PART DESCRIPTION	6•10iN/SK	10•10iN/SK	7•14i/SK
ELECTRICAL/ELECTRONIC PARTS (CONTD.):			
ELEMENT, HEATING, CONVECTION	EL-3854	EL-3761	EL-3761
ELEMENT, HEATING, CONVECTION MNTG HARDWARE			
— WASHERS, FLAT	WS-22294	WS-22294	WS-22294
— WASHERS, SPLIT LOCK	WS-22300	WS-22300	WS-22300
— HEX NUTS	NU-22286	NU-22286	NU-22286
— NUTS	NU-33062	NU-33062	NU-33062
EMI FILTERS, CONTACTOR (380-415V MODEL ONLY)	FI-33990	FI-33990	—
EMI FILTERS, SOLENOID (380-415V MODEL ONLY)	FI-33989	FI-33989	—
FAN, INTAKE, AUXILIARY DC4112NX	FA-3568	FA-3568	FA-3568
FAN, WHEEL	WH-33758	WH-33758	WH-33758
FUSE, SLOW-BLO 2AMP, 250V	FU-33184	FU-33184	FU-33184
FUSE, NEOZED 6.3AMP	FU-33452	FU-33452	FU-33452
FUSE HOLDER, DIN RAIL MOUNT			
— WITH DISCONNECT	FU-33756	FU-33756	FU-33756
— 380-415V, 3PH ONLY	FU-33451	—	—
FUSE HOLDER, 15AMP CLASS G (1PH ONLY)	—	FU-3772	FU-3772
FUSE, 15AMP CLASS G	FU-3775	FU-3775	FU-3775
FUSE, NEOZED 25AMP (380-415V 3PH ONLY)	FU-33449	—	—
FUSE HOLDER, 15AMP, 3POL, CLS G (208-240V 3PH ONLY)	FU-3842	FU-3842	FU-3842
FUSE HOLDER AND COVER, NEOZED (380-415V MODEL ONLY)	FU-33444	FU-33444	—
— ADAPTER RING, FUSE	FU-33448	FU-33448	—
— SUPPORT, FUSE	FU-33445	FU-33445	—
MOTOR CAPACITOR, 12MFD (208-240V, 1PH ONLY)	—	FA-33499	FA-33499
MOTOR CAPACITOR, 25MFD (208-240V, 1PH ONLY)	—	FA-33465	FA-33465
MOTOR, SUB ASSEMBLY (208-240V, 1PH/3PH)	5000465	5000465	5000465
— DETAIL SHAFT	5000276	5000276	5000276
MOTOR, SUB ASSEMBLY (380V, 3PH)	5001093	5000602	—
NUT, KNURLED M3	NU-25095	NU-25095	NU-25095
PANEL, CONTROL OVERLAY PROGRAM OPTIONS (DELUXE MODELS)	PE-25345	PE-25345	PE-25345
PANEL, CONTROL OVERLAY (STANDARD MODELS)	PE-25319	PE-25319	PE-25319
PANEL, CONTROL OVERLAY (DELUXE MODELS)	PE-25048	PE-25048	PE-25048
PANEL LOCK-DOWN SCREW	CL-24089	CL-24089	CL-24089
PROBE, MULTI-POINT CTC	PR-33746	PR-33746	PR-33746
PROBE, OVEN TEMPERATURE (1650mm WIRE LENGTH)	PR-33724	PR-33724	PR-33724

Parts List • Combitherm ML Boiler-Free Smoker Electric

PART DESCRIPTION	6•10iN/SK	10•10iN/SK	7•14i/SK
ELECTRICAL/ELECTRONIC PARTS (CONTD.):			
PROBE, STEAM BYPASS	PR-33751	PR-33751	PR-33751
PROBE SEAL, THERMOCOUPLE	SA-25061	SA-25061	SA-25061
RELAY, PANEL MOUNT	RL-33483	RL-33483	RL-33483
SWITCH, MOTOR PROTECTION (208-240v, 1PH ONLY) (3PH ONLY)	— SW-33378	SW-33500 SW-33378	SW-33500 SW-33378
TERMINAL, GROUND, 4mm	TM-3781	TM-3781	TM-3781
TERMINAL, GROUND, 10mm	TM-3932	TM-3932	TM-3932
TERMINAL PARTITION, 4mm	TM-3783	TM-3783	TM-3783
TERMINAL PARTITION, 16mm	TM-3785	TM-3785	TM-3785
TERMINAL, PLUG	TM-3926	TM-3926	TM-3926
TERMINAL BLOCK X1	TM-33747	TM-33747	TM-33747
TERMINAL BLOCK X2	TM-33748	TM-33748	TM-33748
TERMINAL BLOCK X3	TM-33749	TM-33749	TM-33749
TERMINAL BLOCK X10-X11, 4mm	TM-3778	TM-3778	TM-3778
TERMINAL BLOCK X10, 16mm	TM-3779	TM-3779	TM-3779
— TERMINAL JUMPER BAR (2 POLE)	TM-33675	TM-33675	TM-33675
— TERMINAL JUMPER BAR (3 POLE)	TM-33106	TM-33106	TM-33106
— TERMINAL JUMPER BAR (4 POLE)	TM-3787	TM-3787	TM-3787
THERMOSTAT, HIGH LIMIT	TT-3750	TT-3750	TT-3750
VALVE, TRIPLE SOLENOID	VA-34045	VA-34045	VA-34045
VALVE, SOLENOID (COSTCO MODEL ONLY)	—	—	VA-25481
MECHANICAL PARTS:			
BOX, PRESSURE	5000585	5000585	5000585
BUSHING, MOTOR ASSEMBLY	BU-23894	BU-23894	BU-23894
BUSHING, SOCKET MEMBRANE, VENT	BU-22204	BU-22204	BU-22204
CHIP TRAY — BRACKET	5002674 BT-25900	5002674 BT-25900	5002674 BT-25900
HOLDER, CTC PROBE	13412	13412	13412
HOSE, CLEAR FLEX	HO-22255	HO-22255	HO-22255
HOUSING, SEAL, O-RING	SA-25139	SA-25139	SA-25139
LEGS, 2" (51mm) ADJUSTABLE	LG-23907	LG-23907	LG-23907
LAMP, COVER	CV-23896	CV-23896	CV-23896

Parts List • Combitherm ML Boiler-Free Smoker Electric

PART DESCRIPTION	6•10iN/SK	10•10iN/SK	7•14i/SK
MECHANICAL PARTS (CONTD.):			
LIGHT BULB	LP-3686	LP-3686	LP-3686
LIGHT, GLASS COVER	LP-33413	LP-33413	LP-33413
LIGHT SEAL	SA-23934	SA-23934	SA-23934
LIGHT, SOCKET RECEPTACLE	RP-3986	RP-3986	RP-3986
PROBE PLUG ADAPTOR	PG-3826	PG-3826	PG-3826
PROBE PLUG SEAL	SA-22199	SA-22199	SA-22199
PROBE SEAL, INSERT	SA-22322	SA-22322	SA-22322
PROBE SEAL, CONE	SA-22321	SA-22321	SA-22321
PROBE SEAL, TOP	SA-22320	SA-22320	SA-22320
SCREW COVER, M6 NATURAL	SC-23936	SC-23936	SC-23936
SETUP, BOILERLESS			
— BOX, DISINTEGRATION	1001204	1001204	1001204
— TUBE, INJECTION	5000618	5000618	5000618
— TUBE, INJECTION (WW MODELS ONLY)	5003511	—	—
SHELVES	SH-2903	SH-2903	SH-22584
SIDERACKS	SR-22525	SR-22267	SR-23942
WASHER, CONICAL	13607	13607	13607
PLUMBING PARTS:			
CONDENSER TANK ASSEMBLY	5000608	5002774	5002790
CONDENSER TANK ASSEMBLY (208V MODELS ONLY)	5002774	—	—
CONDENSER TANK ASSEMBLY (WW MODELS ONLY)	5003510	—	—
CONDENSATE TANK COVER NUT	SC-24070	SC-24070	SC-24070
CONDENSATE TANK COVER SCREW	SC-23936	SC-23936	SC-23936
CONDENSER, INJECTION NOZZLE	5000284	5000284	5000284
CONDENSER, O-RING	SA-22212	SA-22212	SA-22212
CONDENSER, O-RING 8X2.5 EPDM	SA-23109	SA-23109	SA-23109
DRAIN, CAP	CP-23895	CP-23895	CP-23895
DRAIN SCREEN	DA-2943	DA-2943	DA-2943

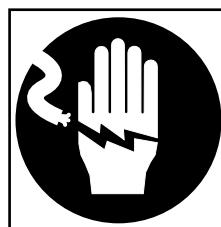

DANGER

**DISCONNECT UNIT FROM
POWER SOURCE BEFORE
CLEANING OR SERVICING.**

Parts List • Combitherm ML Boiler-Free Smoker Electric

PART DESCRIPTION	6•10iN/SK	10•10iN/SK	7•14i/SK
PLUMBING PARTS (CONTD.):			
FILL LINE ASSEMBLY	5002791	5002775	5002791
FILL LINE ASSEMBLY (208V MODELS ONLY)	5002775	—	—
PIPE, DRAIN EXTENSION	PP-26308	PP-26308	PP-26308
PIPE, DRAIN EXTENSION (380-450V, NON-NPE MODELS ONLY)	PP-25137	—	—
HAND SHOWER			
— FULL ASSEMBLY	14442	14442	14442
— BRACKET	PB-23921	PB-23921	PB-23921
— HOSE, BALL VALVE	VA-22684	VA-22684	VA-22684
— VALVE, SPRAY	PB-23919	PB-23919	PB-23919
— HANDLE	PB-23920	PB-23920	PB-23920
— HOSE ASSEMBLY	PB-23922	PB-23922	PB-23922
HOSE, CONNECTOR ELBOW WITH SEAL	HO-22116	HO-22116	HO-22116
HOSE, MEASURING PIPE	5000708	5000620	5000301
HOSE, PUMP	HO-25070	HO-25070	HO-25070
HOSE, RADIATOR	HO-22254	HO-22254	HO-22254
HOSE, STEAM BYPASS	HO-2957	HO-2957	HO-2957
PROBE, MEASURE WELD	5000283	5000283	5000283
SCREEN FILTER	FI-2946	FI-2946	FI-2946
SEALS, O-RING	SA-22209	SA-22209	SA-22209
SEALS, O-RING, GAS VALVE	SA-23691	SA-23691	SA-23691
VALVE, FLOW CONTROL	VA-25549	VA-25549	VA-25549
WATER SUPPLY	5000617	5000617	5000617

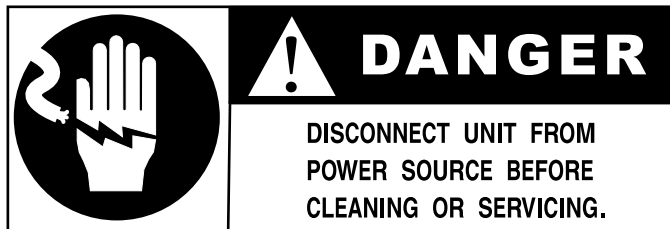

SERVICE VIEW • SIDE PANEL ACCESS

Model 6 • 10iNML

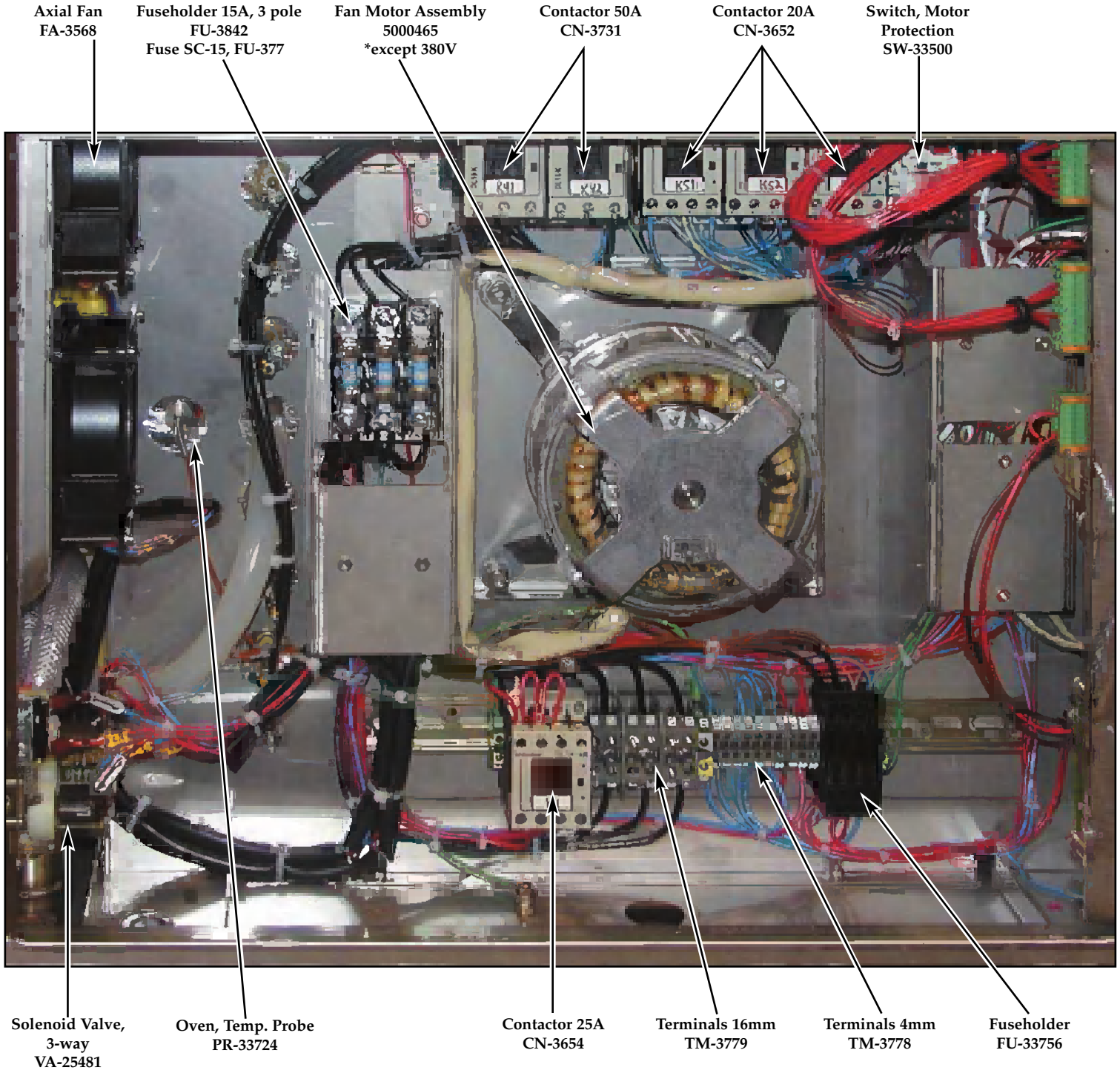

Axial Fan
FA-3568

Fuseholder 15A, 3 pole
FU-3842
Fuse SC-15, FU-377

Fan Motor Assembly
5000465
*except 380V

Contactor 50A
CN-3731

Contactor 20A
CN-3652

Switch, Motor
Protection
SW-33500

Solenoid Valve,
3-way
VA-25481

Oven, Temp. Probe
PR-33724

Contactor 25A
CN-3654

Terminals 16mm
TM-3779

Terminals 4mm
TM-3778

Fuseholder
FU-33756

SERVICE VIEW • BACK PANEL ACCESS

Model 6•10iNML

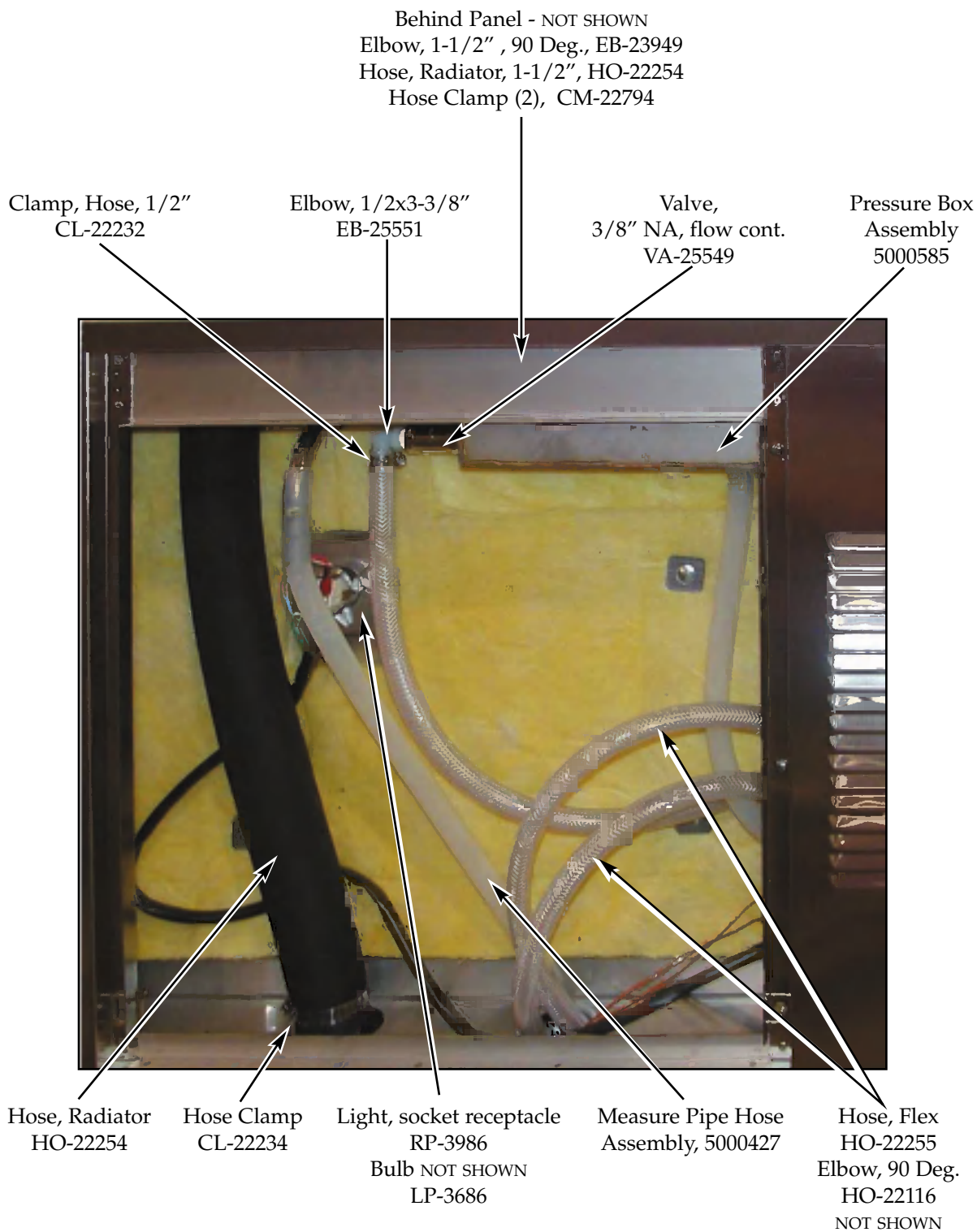

SERVICE VIEW • OVEN INTERIOR

Fan Wheel
WH-33838 - 6•05
WH-33758 - 6•10

Pin, Pivot, s/s
PI-23929 (2)

Direction Panel Assembly
5000694 - 6•05
5000586 - 6•10

Clip, lock CL-24089 (2)
Washer, lock WS-24090 (2)

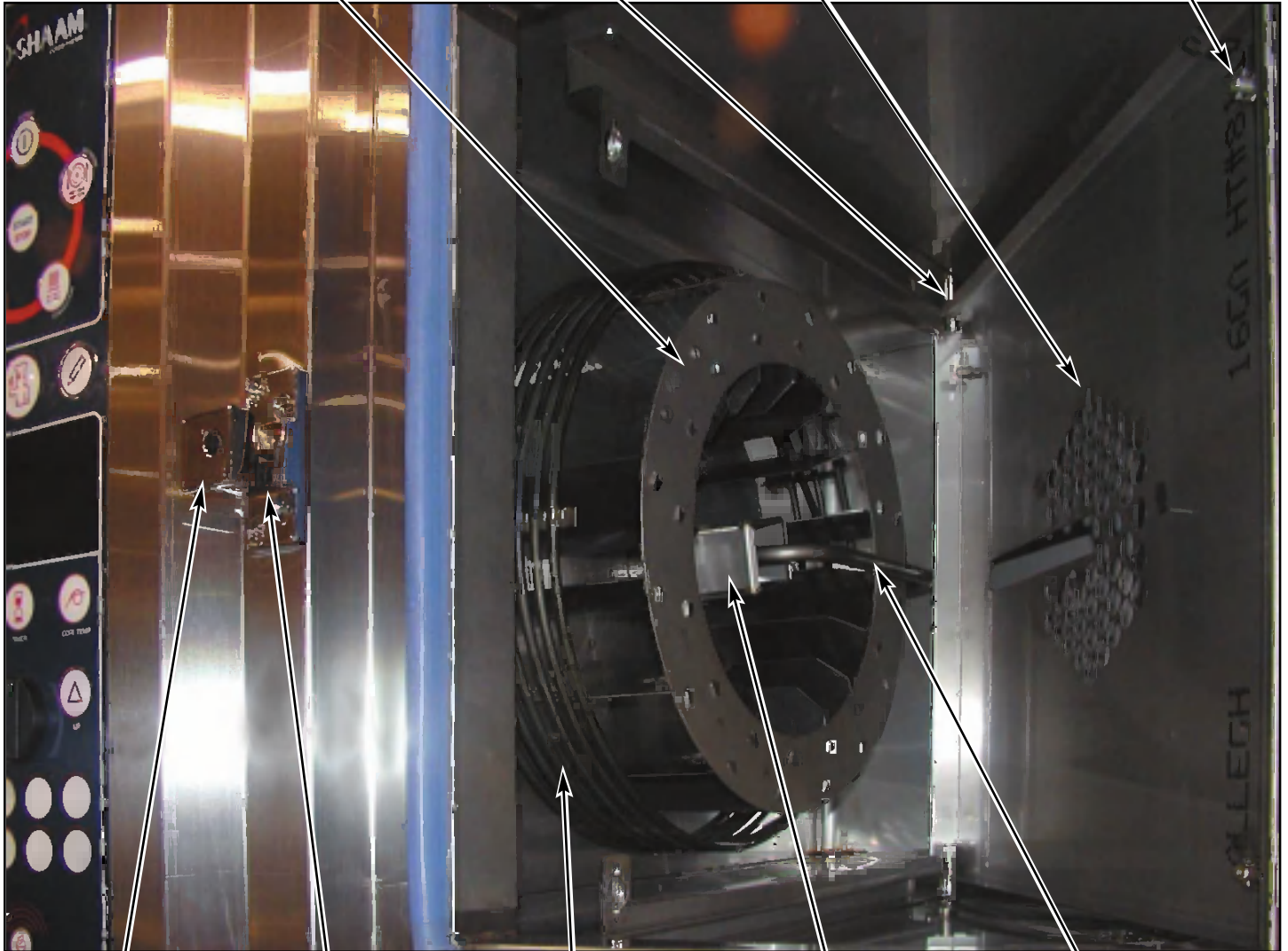

Latch Dowel ONLY
LT-25836

Door Latch
LT-25058

Convection Element
EL-33573 - 6•05
EL-3854 - 6•10

Box, Disintegration
1001204

Injection Tube Weld
5000709 - 6•05
5000618 - 6•10

ALTO SHAAM ORIGINAL EQUIPMENT LIMITED WARRANTY

COMBITHERM®

Alto-Shaam, Inc. warrants to the original purchaser that any original part that is found to be defective in material or workmanship will, at Alto-Shaam's option, subject to provisions hereinafter stated, be replaced with a new or rebuilt part.

The labor warranty remains in effect one (1) year from installation or fifteen (15) months from the shipping date, whichever occurs first. Alto-Shaam will bear normal labor charges performed during standard business hours, and excluding overtime, holiday rates or any additional fees.

The parts warranty remains in effect for one (1) year from installation or fifteen (15) months from the shipping date, whichever occurs first.

THIS WARRANTY DOES NOT APPLY TO:

1. Replacement of light bulbs.
2. Equipment damage caused by accident, shipping, improper installation or alteration.
3. Steam generator or steam generating system damage as a direct result of inadequate routine maintenance and cleaning. Required maintenance and cleaning of steam generating equipment is the responsibility of the owner/operator.
4. Equipment used under conditions of abuse, misuse, carelessness or abnormal conditions including, but not limited to, equipment subjected to harsh or inappropriate chemicals including, but not limited to, compounds containing chloride or quaternary salts, poor water quality, or equipment with missing or altered serial numbers.
5. Damage incurred as a direct result of poor water quality and/or surfaces affected by water quality. Water quality and required maintenance of steam generating equipment is the responsibility of the owner/operator. The installation and use of Alto-Shaam's CombiGuard™ Water Filtration System is highly recommended.

ALTO-SHAAM COMBITHERM WATER QUALITY RECOMMENDATIONS		
CONTAMINANT	INLET WATER REQUIREMENTS WITHOUT COMBIGUARD WATER FILTER	INLET WATER REQUIREMENTS WITH COMBIGUARD WATER FILTER*
Free Chlorine	Less than 0.1 ppm (mg\L)	Less than 2.5 ppm (mg\L)
Hardness	Less than 3 gpg (52 ppm)	Up to 16 gpg (274 ppm)
Chloride	Less than 30 ppm (mg\L)	Less than 150 ppm (mg\L)
pH	7.0 to 8.5	7.0 to 9.0
Alkalinity	Less than 50 ppm (mg\L)	Up to 150 ppm (mg\L)
Total Dissolved Solids (TDS)	Less than 125	Up to 500

*COMBI-GUARD FILTER REPLACEMENT MUST BE MADE AT REQUIRED INTERVALS.

6. Damage caused by use of any cleaning agent other than Alto-Shaam's Combitherm® Oven Cleaner including, but not limited to, damage due to chlorine or other harmful chemicals. Use of Alto-Shaam's Combitherm Cleaner on Combitherm ovens is highly recommended.
7. Any losses or damage resulting from malfunction, including loss of product or consequential or incidental damages of any kind.
8. Equipment modified in any manner from original model, substitution of parts other than factory authorized parts, removal of any parts including legs, or addition of any parts.

This warranty is exclusive and is in lieu of all other warranties, expressed or implied, including the implied warranties of merchantability and fitness for a particular purpose. In no event shall Alto-Shaam be liable for loss of use, loss of revenue or profit, or loss of product, or for any indirect or consequential damages.

No person except an officer of Alto-Shaam, Inc. is authorized to modify this warranty or to incur on behalf of Alto-Shaam any other obligation or liability in connection with Alto-Shaam equipment.

Alto-Shaam, Inc.

ALTO SHAAM. TRANSPORTATION DAMAGE AND CLAIMS

COMBITHERM®



All Alto-Shaam equipment is sold F.O.B. shipping point, and when accepted by the carrier, such shipments become the property of the consignee.

Should damage occur in shipment, it is a matter between the carrier and the consignee. In such cases, the carrier is assumed to be responsible for the safe delivery of the merchandise, unless negligence can be established on the part of the shipper.

1. Make an immediate inspection while the equipment is still in the truck or immediately after it is moved to the receiving area. Do not wait until after the material is moved to a storage area.
2. Do not sign a delivery receipt or a freight bill until you have made a proper count and inspection of all merchandise received.
3. Note all damage to packages directly on the carrier's delivery receipt.
4. Make certain the driver signs this receipt. If he refuses to sign, make a notation of this refusal on the receipt.
5. If the driver refuses to allow inspection, write the following on the delivery receipt:

Driver refuses to allow inspection of containers for visible damage.

6. Telephone the carrier's office immediately upon finding damage, and request an inspection. Mail a written confirmation of the time, date, and the person called.
7. Save any packages and packing material for further inspection by the carrier.
8. Promptly file a written claim with the carrier and attach copies of all supporting paperwork.

We will continue our policy of assisting our customers in collecting claims which have been properly filed and actively pursued. We cannot, however, file any damage claims for you, assume the responsibility of any claims, or accept deductions in payment for such claims.

RECORD THE MODEL AND SERIAL NUMBER OF THE APPLIANCE FOR EASY REFERENCE. ALWAYS REFER TO BOTH MODEL AND SERIAL NUMBER IN ANY CONTACT WITH ALTO-SHAAM REGARDING THIS APPLIANCE.

Model: _____
Serial Number: _____
Date Installed: _____
Voltage: _____
Purchased From: _____



Alto-Shaam has established a twenty-four hour emergency service call center to offer immediate customer access to a local authorized service agency outside of standard business hours. The emergency service access is provided exclusively for Alto-Shaam equipment and is available throughout the United States through the use of Alto-Shaam's toll-free number. Emergency service access is available seven days a week including holidays.